

RABLE

Installation Manual

RABLE4Roofs

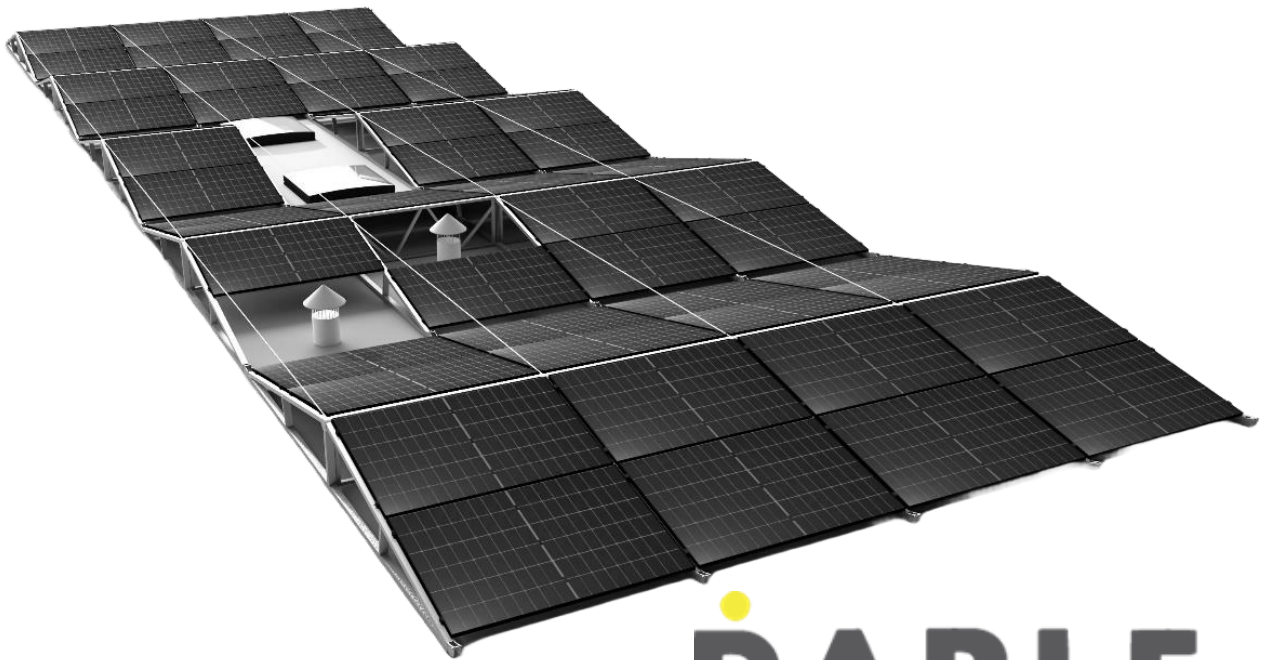

RABLE
Unlocking the solar energy potential of all

RABLE Series E/W Standard

Table of Contents

1.	General	2
1.1	Parts list	5
1.2	General dimensions of the mounting system	6
1.3	Panel clamp mounting positions	6
1.4	Crossing a roof crest	7
2.	Preparation	7
2.1	Recommended tools	7
2.2	Layout and anchor plan	7
2.3	Roof preparation	8
3.	Installing RABLE4Roofs	8
3.1	Pre-install roof anchors [OPTIONAL]	9
3.2	Installing the RABLE4Roofs	9
	Unfolding the side	9
	Attaching extra support feet [OPTIONAL]	10
	Positioning the side	10
	Attaching the center	11
	Installing roof anchors	14
	Attaching the middle center brackets	17
	Attaching the end center brackets	19
	Tightening all fasteners	21
	Attachment of the anchors	22
	Pre-mounting tension cables	24
	Attachment of optimizers	26
	Cable management	27
	Mounting of solar panels	29
	Grounding and potential equalization.	33
4.	Maintenance	33
	Removal and disposal	33

1. General

This manual provides a step-by-step instruction of the installation of the RABLE4Roofs mounting system. Make sure to keep this manual for future use.

At RABLE we strive for continuous improvement, therefore it's possible the product can deviate from the description in this manual. This manual is intended as a guideline for the installation of the product mentioned in the manual. The manufacturer cannot take responsibility for possible errors in the manual, or the consequences of these errors.



User description

This document is intended for installers of the RABLE mounting system. The RABLE mounting system should only be installed by trained installers who have read and understood the details, notes and advice in this document. Please refer to the website for the latest version of this document. RABLE reserves the right to change the document at any time without notice.

Intended use and reasonably foreseeable misuse

The RABLE mounting system allows mounting solar panels on all flat roofs. Installation of the RABLE mounting system must only be complied with according to the steps described in this document. Any other form of installation is considered improper use and may lead to injury, damage to the system and void warranty and product liability claims.

Used icon

Icons	Meaning
	<p>This symbol indicates a hazardous situation which, if not avoided, could result in serious injury or death.</p>
	<p>This symbol indicates useful additional information and tips.</p>

Safety precautions

When installing the RABLE mounting system, this document and the national regulations of the country of installation must always be followed to prevent accidents. If in doubt, consult your safety officer. Ensure that any safety or health hazards are reported to the employer, supervisor, and executing worker. Pay particular attention to the standards, regulations, and guidelines described in this section.

Safety equipment

RABLE advises to always wear personal protective equipment (PPE) during installation of the RABLE mounting system;

safety helmet, mandatory during lifting operations and when overhead work is carried out.

Hearing protection

Safety glasses

Safety clothing

Safety gloves

Safety shoes



Safety instructions



- Always follow the national safety regulations of the country of installation.
- During installation, always use the layout and anchor plan derived from the final layout plan.
- Always provide suitable safety measures such as fall protection on the roof.
- Make sure the roof is clean and empty before installation.
- Check that the prepared layout and anchor plan is suitable and always keep two copies of the plan handy.
- Check prior to the installation if the roof covering and/or insulation is capable of withstanding the pressure executed by the mounting structure.
- Check whether the roof covering is suitable for the anchor placement of the RABLE4Roofs.
- If in doubt about any of the above, consult a roofer and/or structural engineer.

General safety

NOTE

- Check that the delivery is complete before starting the installation.
- Never walk on the system or solar modules.
- Be careful of sharp parts that could potentially damage the roof covering.
- Ensure that packages cannot blow away.
- Avoid installation in strong winds and/or a wet roof surface.

Netherlands: Working Conditions Decree, Articles 3.16, 7.23, and 8.1 to 8.3.

- Installation of the RABLE mounting system needs to be carried by qualified personnel.
- Avoid installation during extreme weather conditions for instance strong winds or icy conditions.
- During roof installation, always use roof edge protection and, if necessary, fall protection and safety nets.
- **Warning:** Ensure that during the installation of the mounting system, hands and/or fingers do not get trapped in the hinged parts!

Standards and regulations

Make sure to follow the applicable standard and regulations for a safe and correct installation.

For Europe:

- NEN-EN 1990
- NEN-EN 1991-1-3-NB
- NEN-EN 1991-1-4-NB

For the Netherlands:

- NEN 7250
- SCOPE 12
- NEN 1010



Warranty

Warranty applies according to the warranty and general terms and conditions of RABLE B.V. These can be found at www.rable.com.

1.1 Parts list

Article number	Name
10-010-0007	R4R Side
10-020-0001	R4R Center 1722 mm
10-020-0002	R4R Center 1762 mm
10-020-0003	R4R Center 1903 mm
10-020-0005	R4R Center Custom
20-050-0001	Cable standard 5mm
30-030-0010	M8 Stainless steel flange nut
30-030-0048	M10x55 Stainless bolt
30-030-0049	M10 Lock nut
10-060-0007	Support feet
20-060-0006	Panel clamp
30-030-0018	Connecting pin
30-030-0035	Cable management clip
20-010-0004	Center connection bracket

Required special tools for installation

Article number	Name	Image
20-060-0023	Allen Key 6mm	
20-060-0033	13mm extended socket	
20-060-0034	Multipurpose RABLE tool	

1.2 General dimensions of the mounting system

In the drawing below the general dimensions of the mounting system, including the positions of the roof anchors, are displayed. The total length (L) can be determined by the number of frames in X-direction (NbX) multiplied with 4.8 meters. For the maximum width (B), the formula in the drawing below can be used depending on the number of frames in the Y-direction (NbY) and the length of the panel (PL).

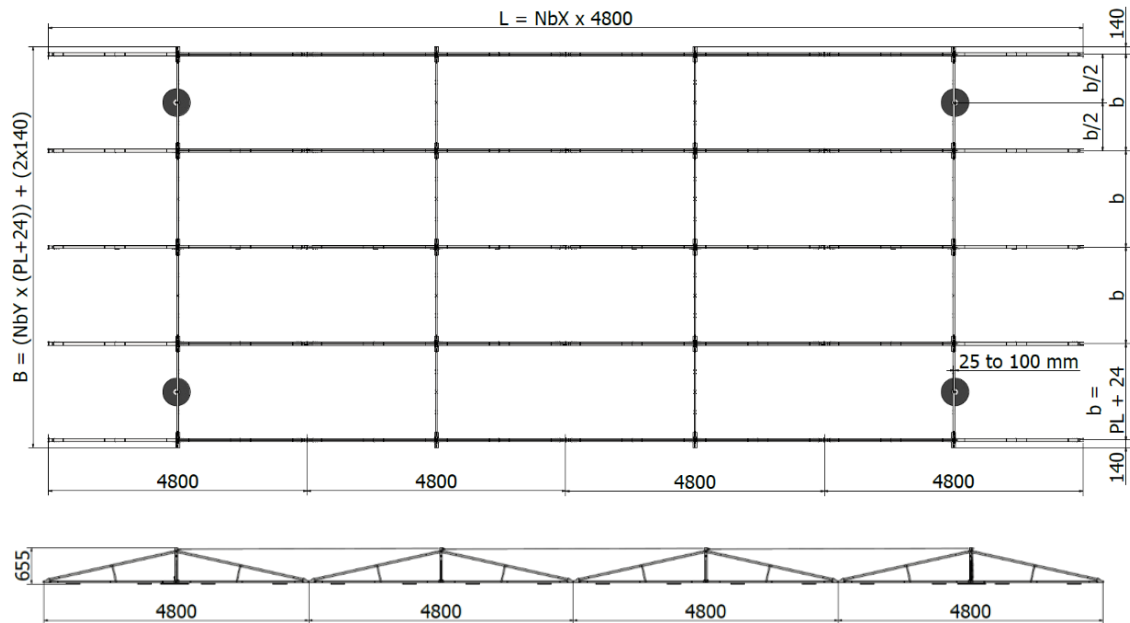

1.3 Panel clamp mounting positions

In the drawing below, the distances of the panel clamp mounting positions are shown. Always check if the mounting positions of the panel clamps are in accordance with the solar panel manufacturers manual.

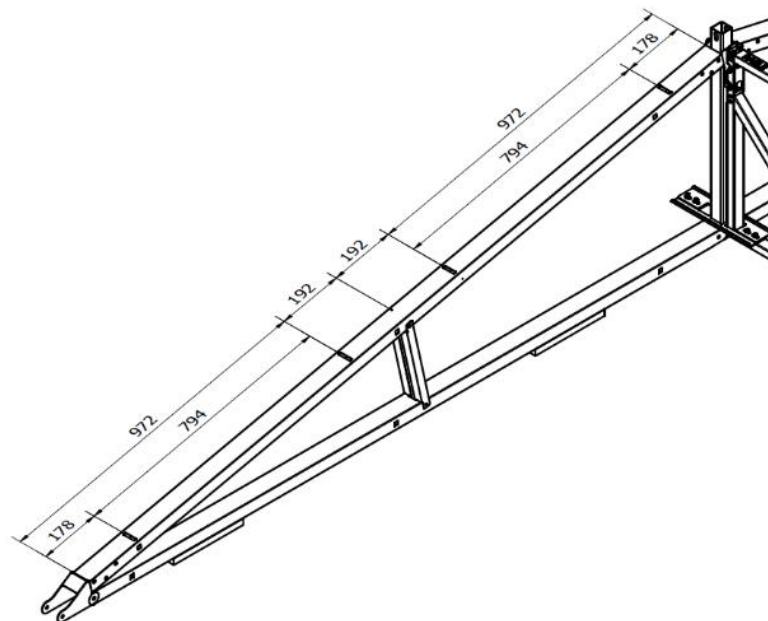

1.4 Crossing a roof crest

The length of the steel cable is adjustable in such a way that crossing a roof crest is possible. In the drawing below, the maximum slopes between the two roof sections are described. It is possible to cross a roof crest with a maximum slope of each roof section of 1.5° . An angle of 1.5° is equivalent to a slope of 26 mm/m

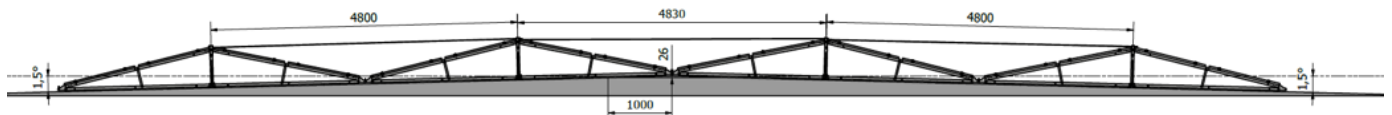

2. Preparation

2.1 Recommended tools

- Marking tools (e.g. chalk)
- Tape measure
- Chalk line
- Electric drill
- 17- & 15-mm Wrench (or adjustable wrench)

2.2 Layout and anchor plan

NOTE

By using the **online calculator** of RABLE (www.rable.com/calculator), one can design a layout-plan after free registration. If you are in need of help with designing your layout-plan, please contact RABLE.

Please send your layout-plan to support@rable.com for a detailed validated anchor plan.

RABLE provides an anchor plan. Based on this plan, the PV installation can be installed using the RABLE mounting system.

The information provided in the calculator-report is for reference only. Precise specifications and guidelines regarding the weight and load of the system, including its own weight, are given. The total weight may vary depending on the added solar panels. No rights can be derived from RABLE's advice. It is therefore important that the information given is verified and analysed by a qualified professional.

The installation plan is based on Google Maps and Google Earth images. RABLE is not responsible for inaccuracies or deviations that may arise from the use of these images. The layout plan serves only as a guideline from which no rights can be derived.

Based on the data provided by the client, the load per square meter has been calculated by RABLE's online calculator.

Based on the anchor plan, the maximum tensile force required at the anchor point is 150 kg.
If other values are required, please contact RABLE.

2.3 Roof preparation

- Check the project plan (layout and anchor plan). Always keep this document on hand.
- Prepare the necessary tools and inspect the delivered components for completeness.
- Ensure that the roof surface where the work will be carried out is clean and dry.
- Prevent bulging of the roof covering, as this can cause unwanted displacement of the mounting system in extreme cases. It is the installer's responsibility to prevent bulging of the roof.

3. Installing RABLE4Roofs

Before installing the system, RABLE recommends drawing a right angle, as depicted in the drawing below, to easily align the mounting system. Use the project plan and the dimensions of the mounting system to draw a right angle at the required distance from the roof edge. Determine the required space and distance to the roof edge, depending on the project plan.

1. RABLE recommends keeping a minimal clear distance of 50 cm around the field for sufficient walking space.
2. Draw the straight angle along the roof edge using the 3-4-5 rule, with a tape measure and a chalk line.

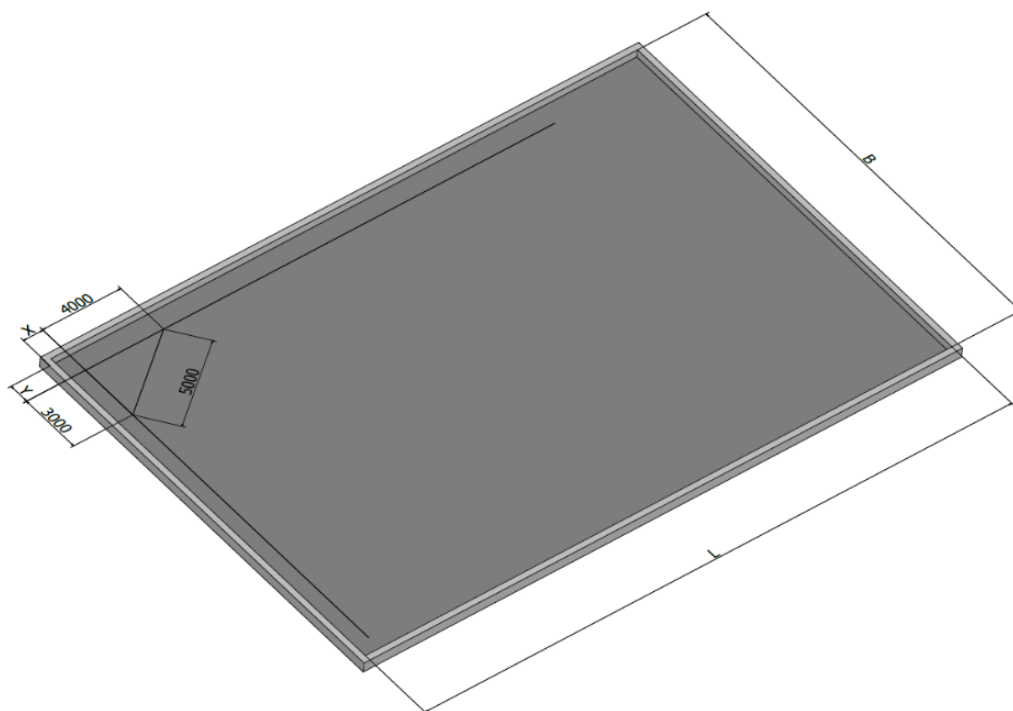

3.1 Pre-install roof anchors [OPTIONAL]

It is possible to pre-install the roof anchors prior to installing the RABLE4Roofs. Depending on the dimensions of the field, the positions of the roof anchors can be obtained from the drawings in section 1.2 and the project plan.

3.2 Installing the RABLE4Roofs

Unfolding the side

- Start by unfolding one side at the starting corner of the field.

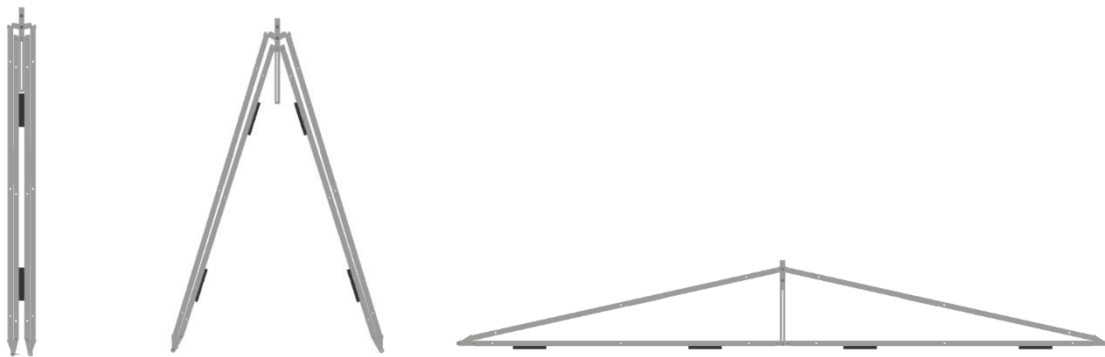

- After unfolding the side, unfold the braces (two per side) as shown in the pictures below

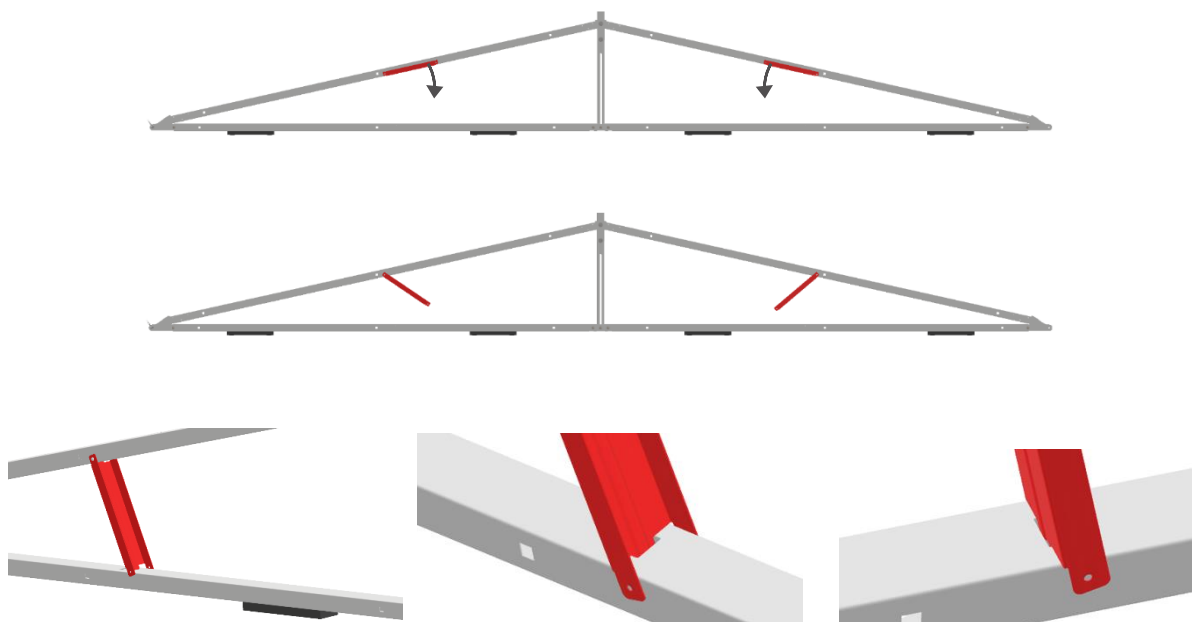

Attaching extra support feet [OPTIONAL]

If needed, additional support feet can be added underneath the side for extra support or to reduce pressure on the roofing material. Additional support feet can be ordered (Article number 10-060-0007)

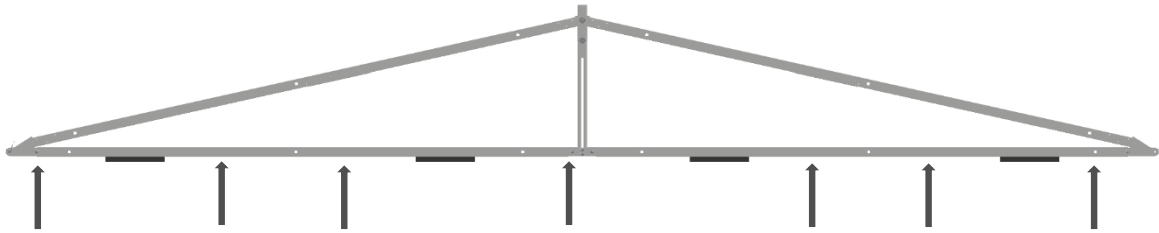

Additional feet can be placed on the positions of arrows.

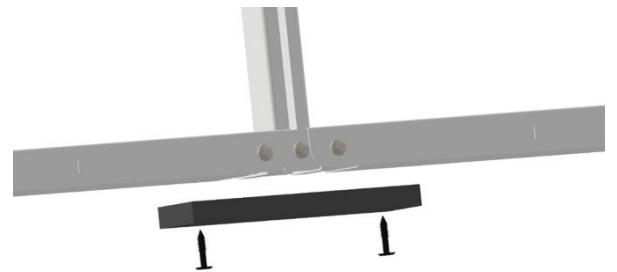

Positioning the side

Position the first side along the right angle drawn on the roof.

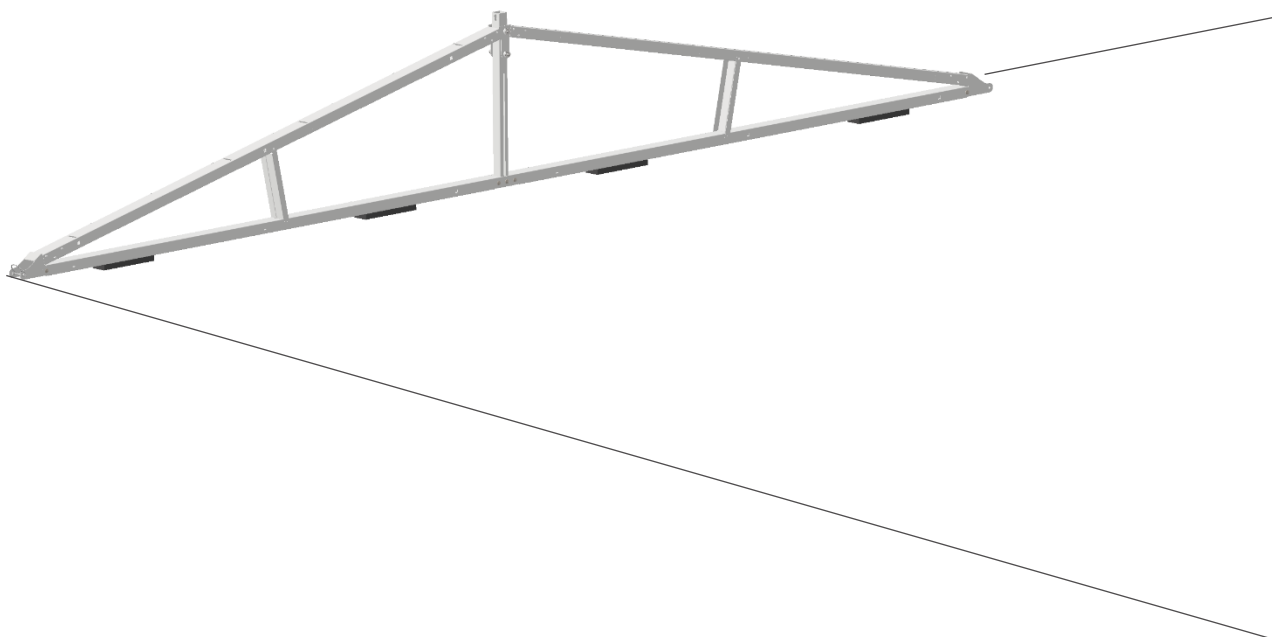

Attaching the center

To attach the center, follow these steps:

- Un-tighten the pre-assembled bolt washer combination, but leaving the bolt and washer attached to the side.



- Attach the panel specific center using the predefined cutouts in the corners of the center. Slide the cutout section over the bolt-washer combination. When the top bolt has slid into the top cutout, move the center downwards

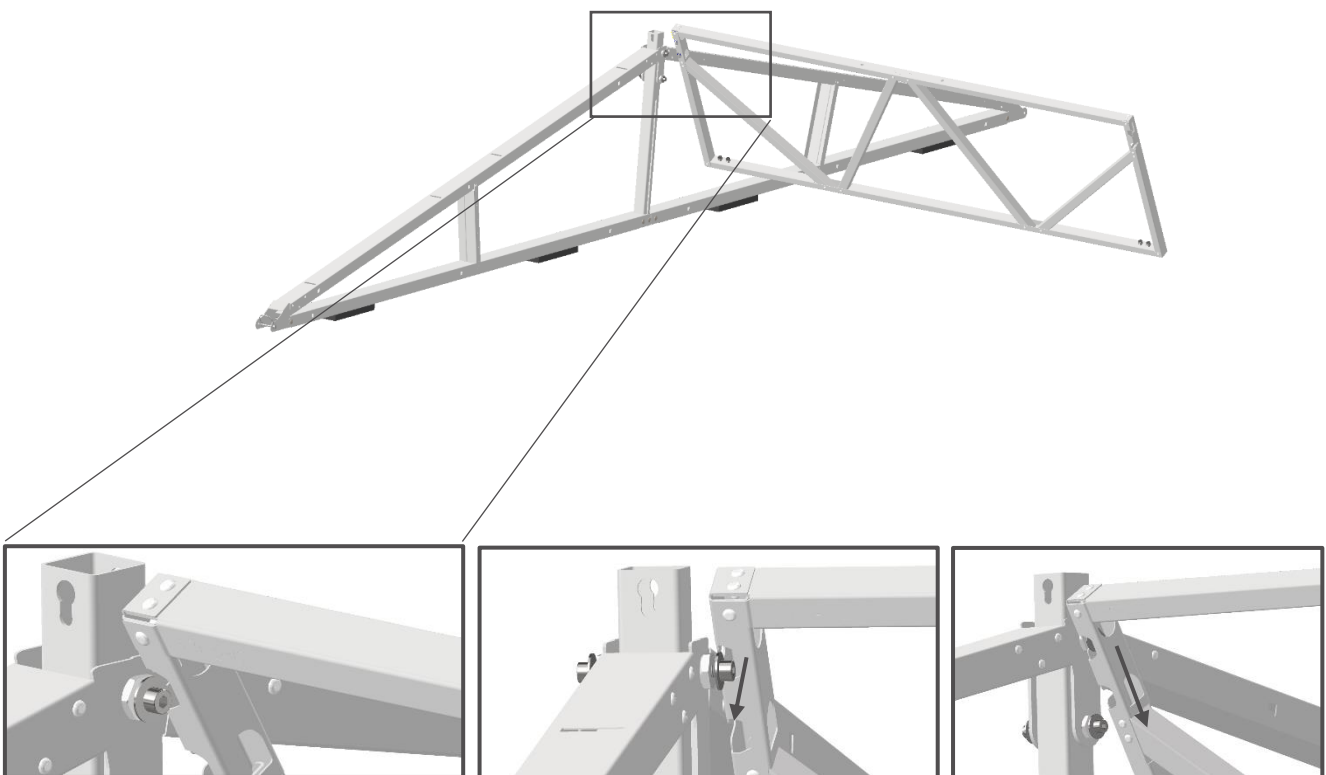

- After the top bolt is in the top of the center, rotate the center towards its horizontal position. In this way, the second bolt-washer combination will be placed in its dedicated cutout.

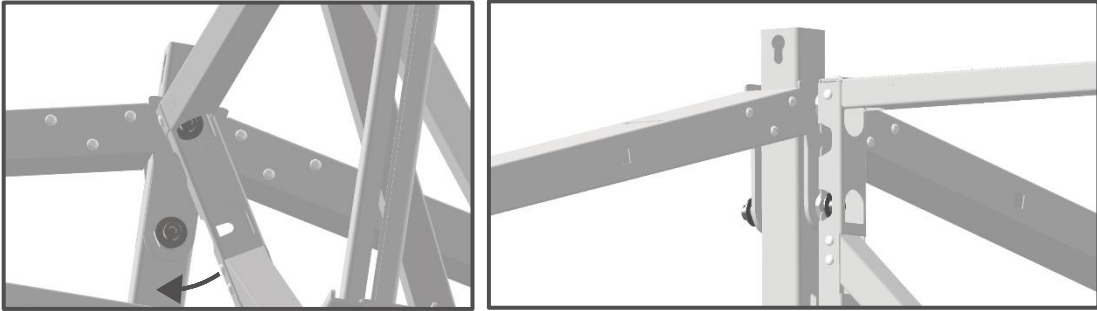

NOTE

Do not tighten the bolts yet! This is done in a later stage.



- Repeat the unfolding procedure of the side as described before and attach the second side to the center as shown in the previous step.

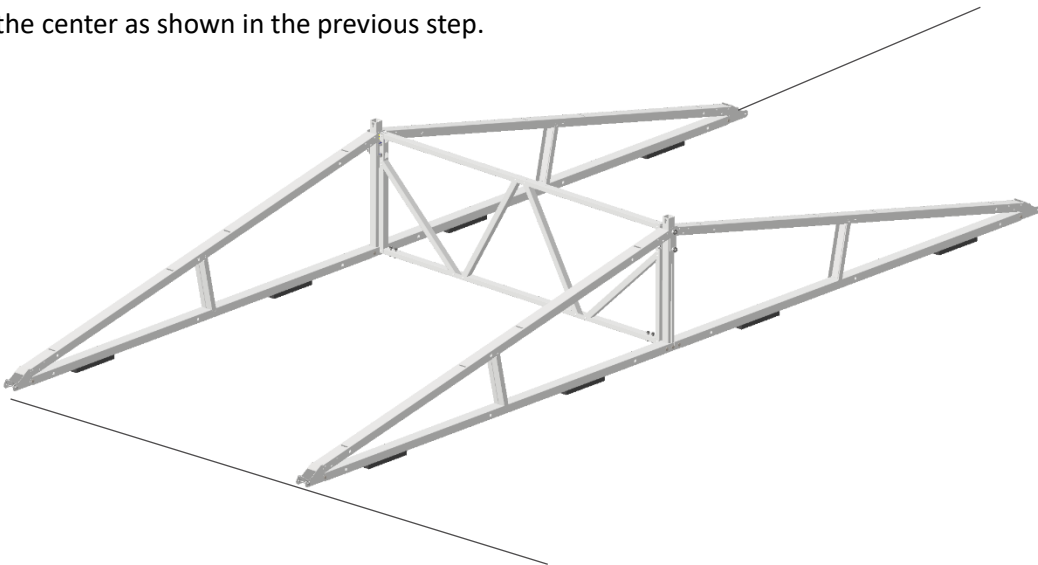

- Continue the previous steps until the first row (Y-direction) is complete. *Check the project plan for the number of modules.*

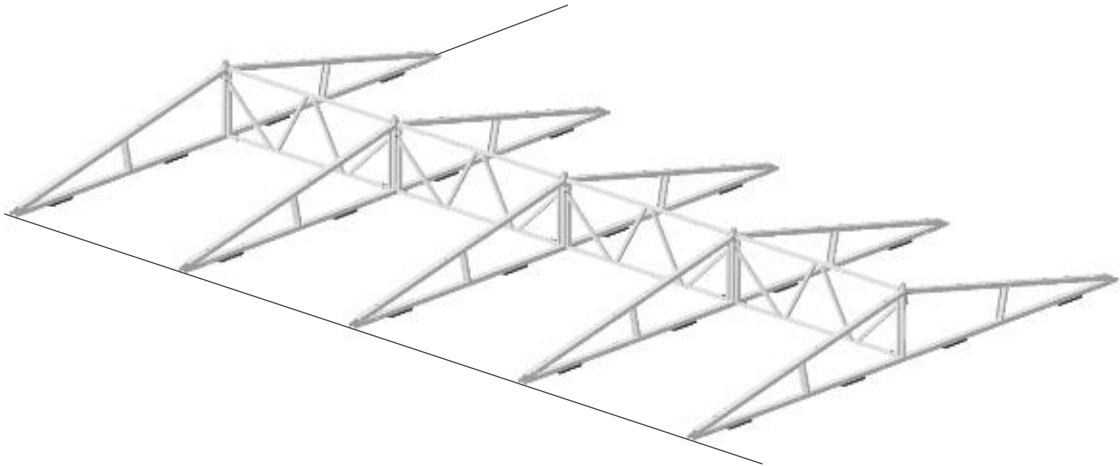

- To extend the field in the column (X) direction, unfold the side and connect using the pre-mounted connecting pin. Unfold the retaining clip and remove the connecting pin, slide the side connection plates to the previously installed sides. Slightly fold the connecting plates of the new side inwards and reconnect the connecting pin.

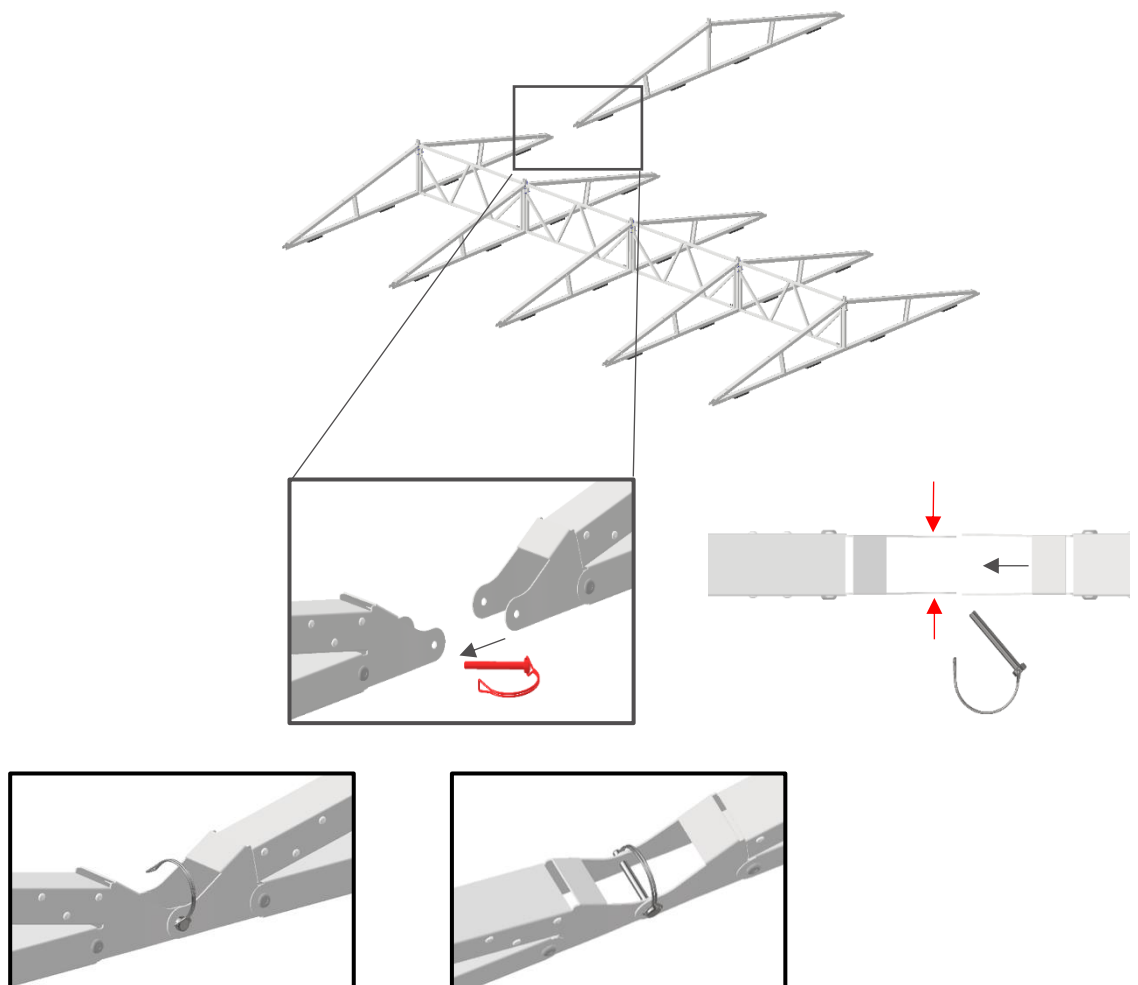

- Continue installing the remaining field as described in the previous steps.

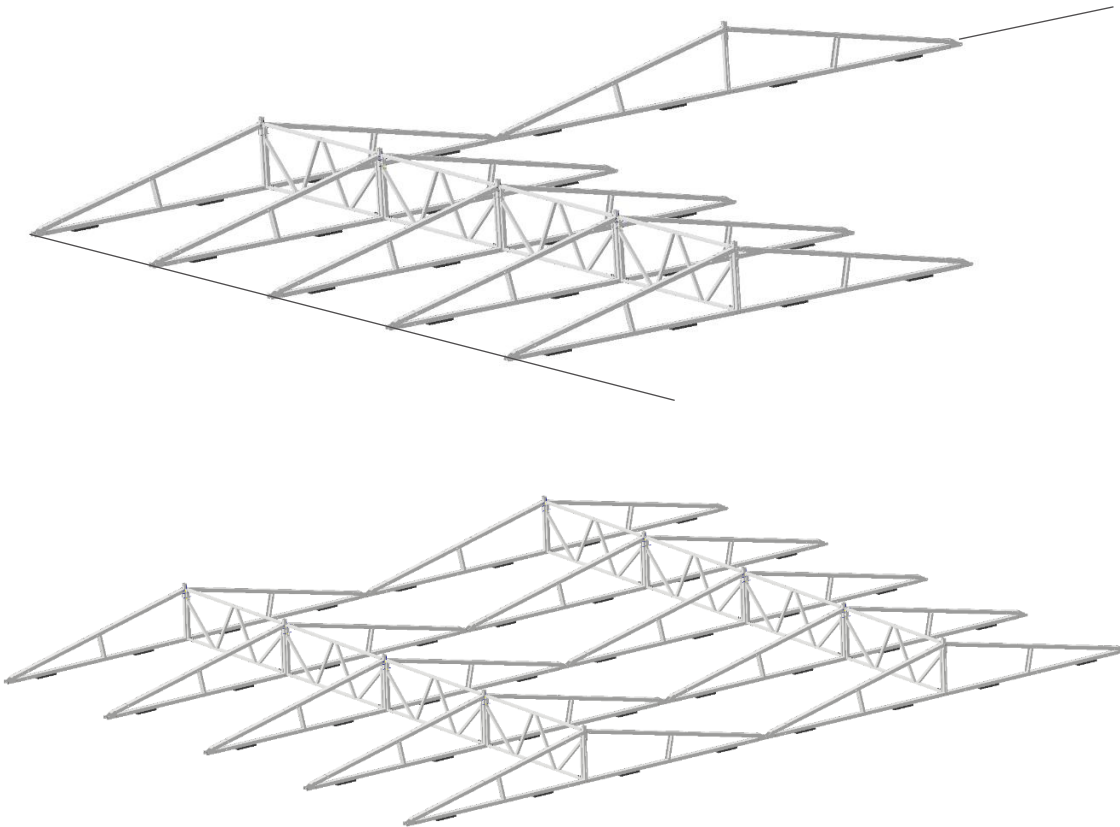

Installing roof anchors

In case the optional approach of placing the roof anchors before installing the mounting system (see

Pre-install roof anchors [OPTIONAL] is not executed, the roof anchors need to be installed.

Refer to the “**Project plan**” for the locations of the roof anchors. The amount and positions of anchors are determined specifically for each project depending on various parameters such as height of the building, wind zone and environment. Do not deviate from the project plan.

Please refer to the supplier of the roof anchor for the installation instructions of the roof anchors.
Place the roof anchors at the end of the construction process as indicated in the project plan

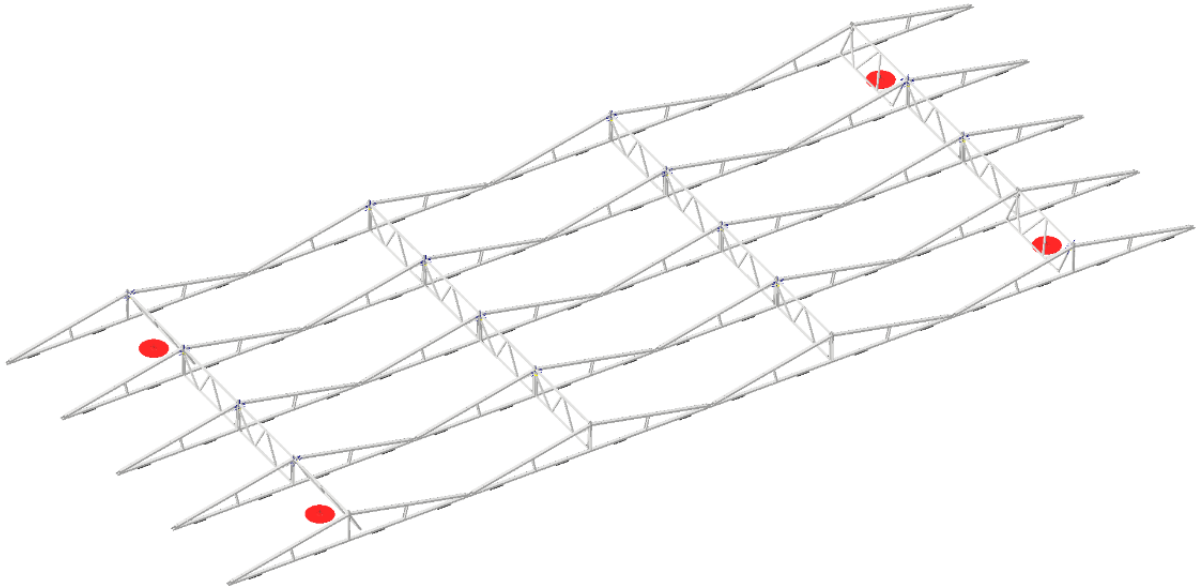

To easily install the roof anchors, it is possible to tilt the center in such a manner it doesn't obstruct the installation of the roof anchors. Tilt the centers at the locations of the anchors and mount the anchors.

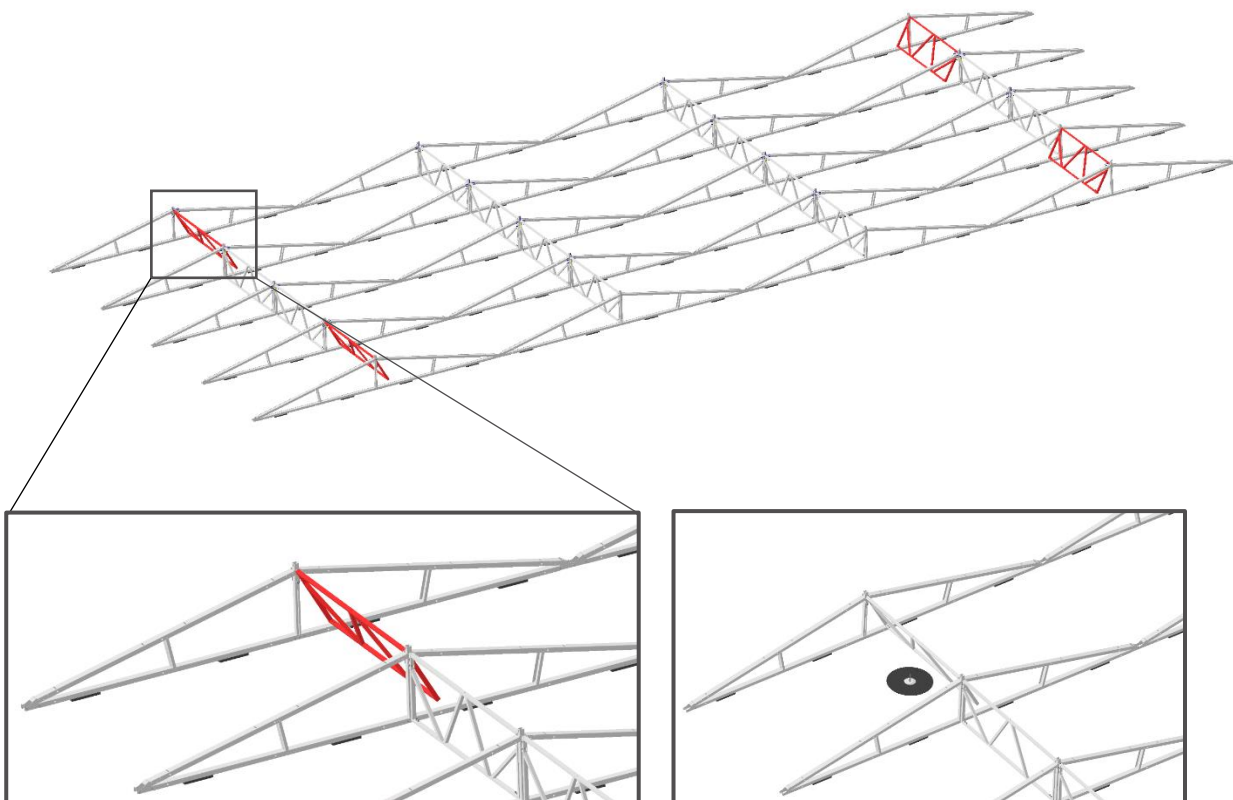

Attaching the middle center brackets

- After installing the roof anchors, the next step is to attach the center brackets. These brackets are attached to the lower section of the centers. To attach the center brackets, undo the pre-mounted M8 Flange nuts located at the lower section of the center as depicted in the drawing below.

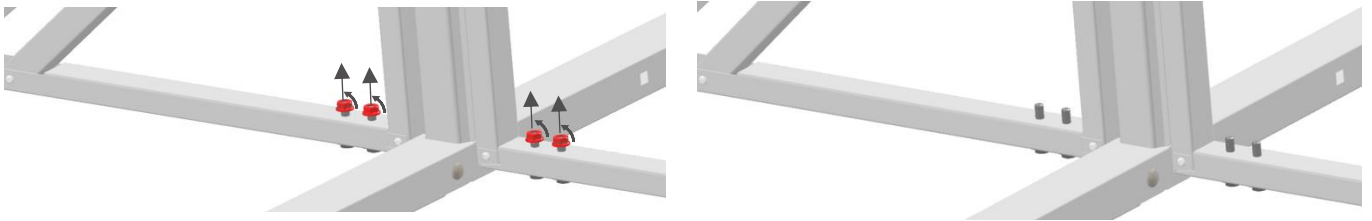

- After unscrewing the flange nuts, place the **first** center bracket:

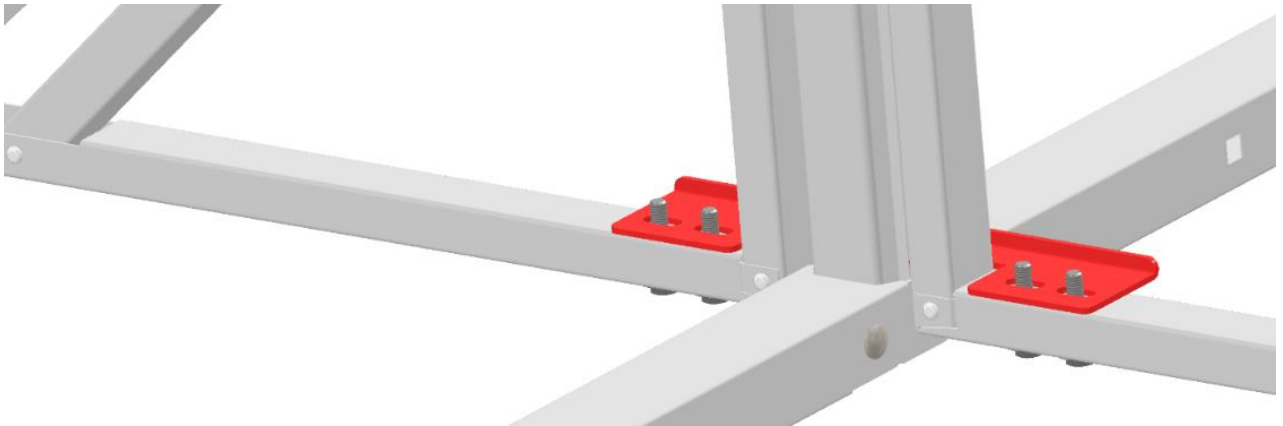

- Place the **second** center bracket on top of the first bracket

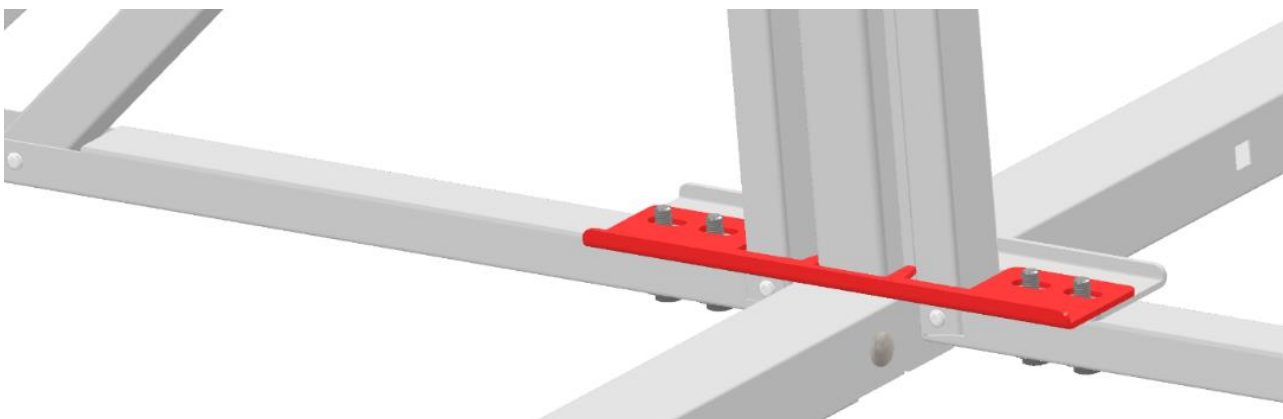

- Re-attach the flange nuts on the bolts.

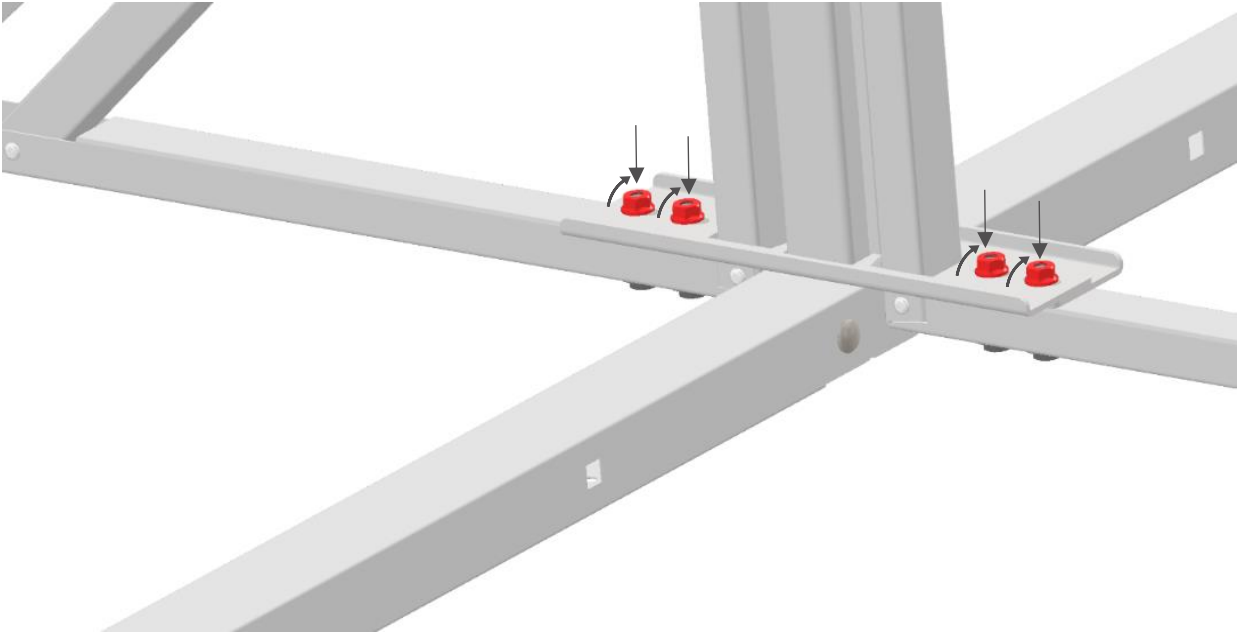

- Repeat the previous steps for all the center brackets within the circles below.

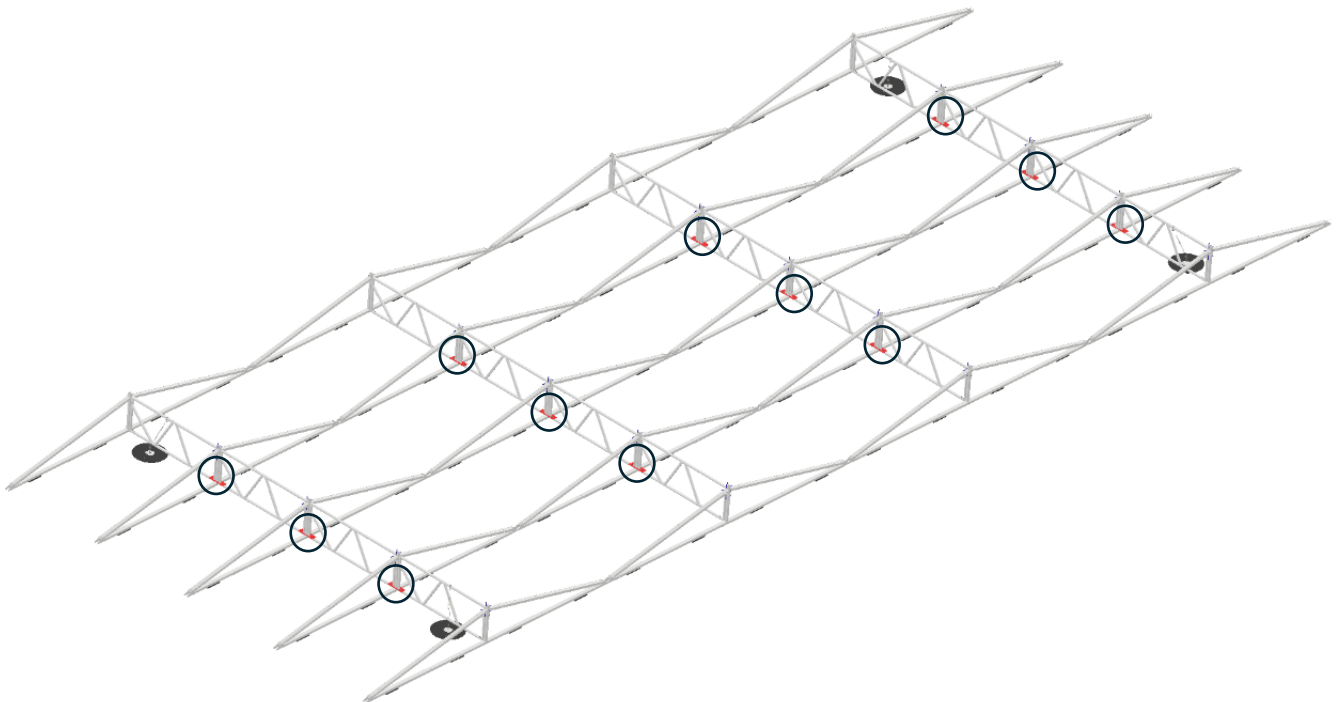

Attaching the end center brackets

Attaching the center brackets at the end of the fields is the same principle as the middle brackets.

- Unscrew the pre-assembled M8 flange nuts on the bottom of the center.

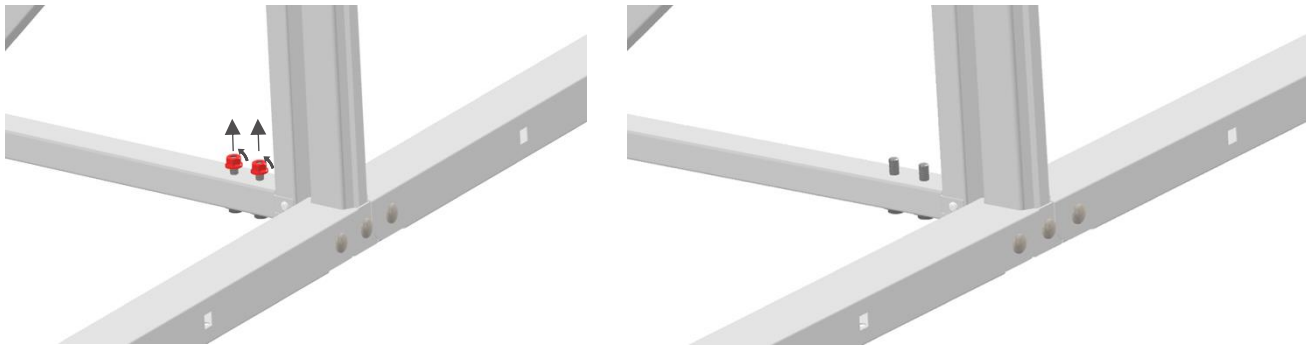

- Place the two center brackets as depicted in the drawing below.

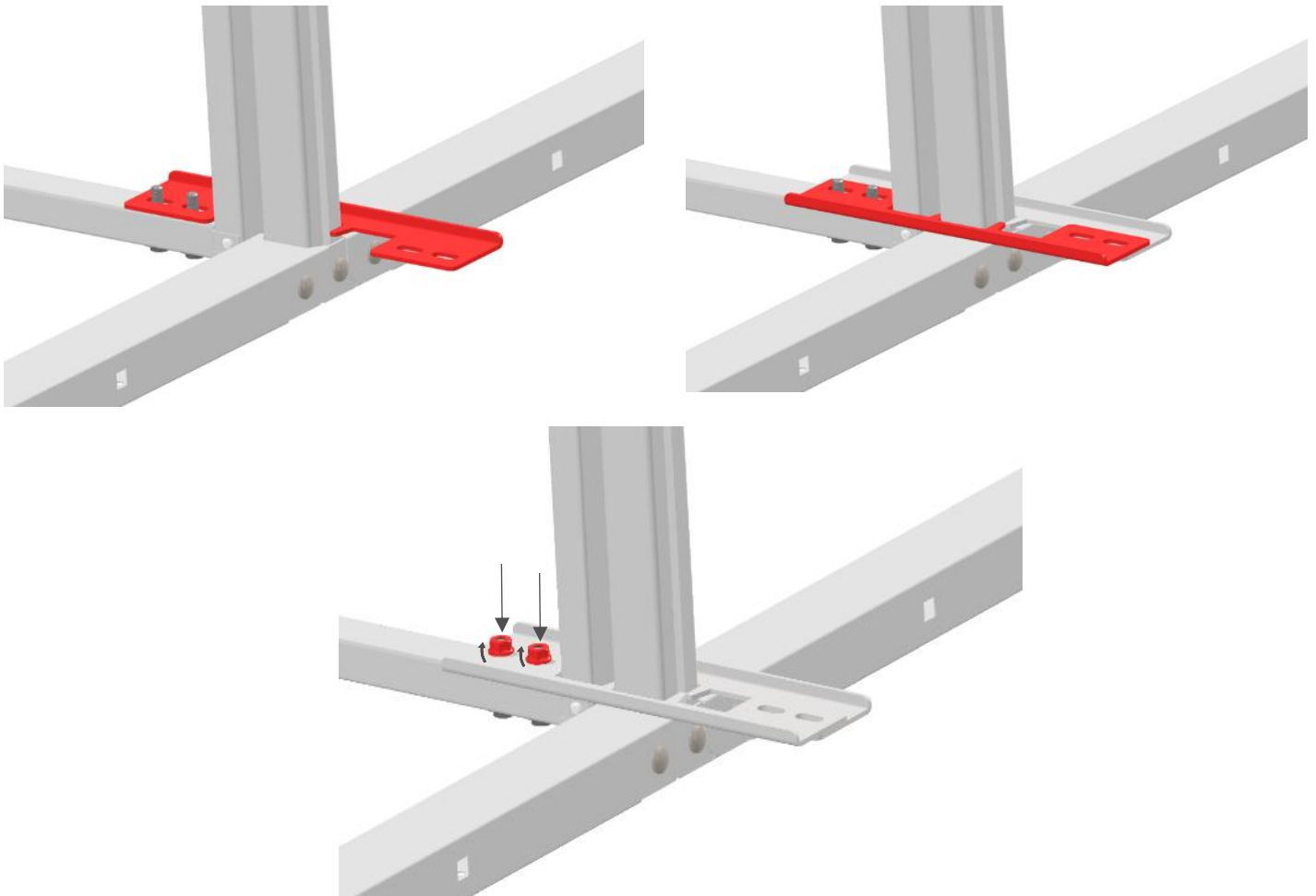

Use the two M8x16 mm allen bolt on the top of the side and the separately provided M8 flange nuts to attach the outside section of the center brackets.

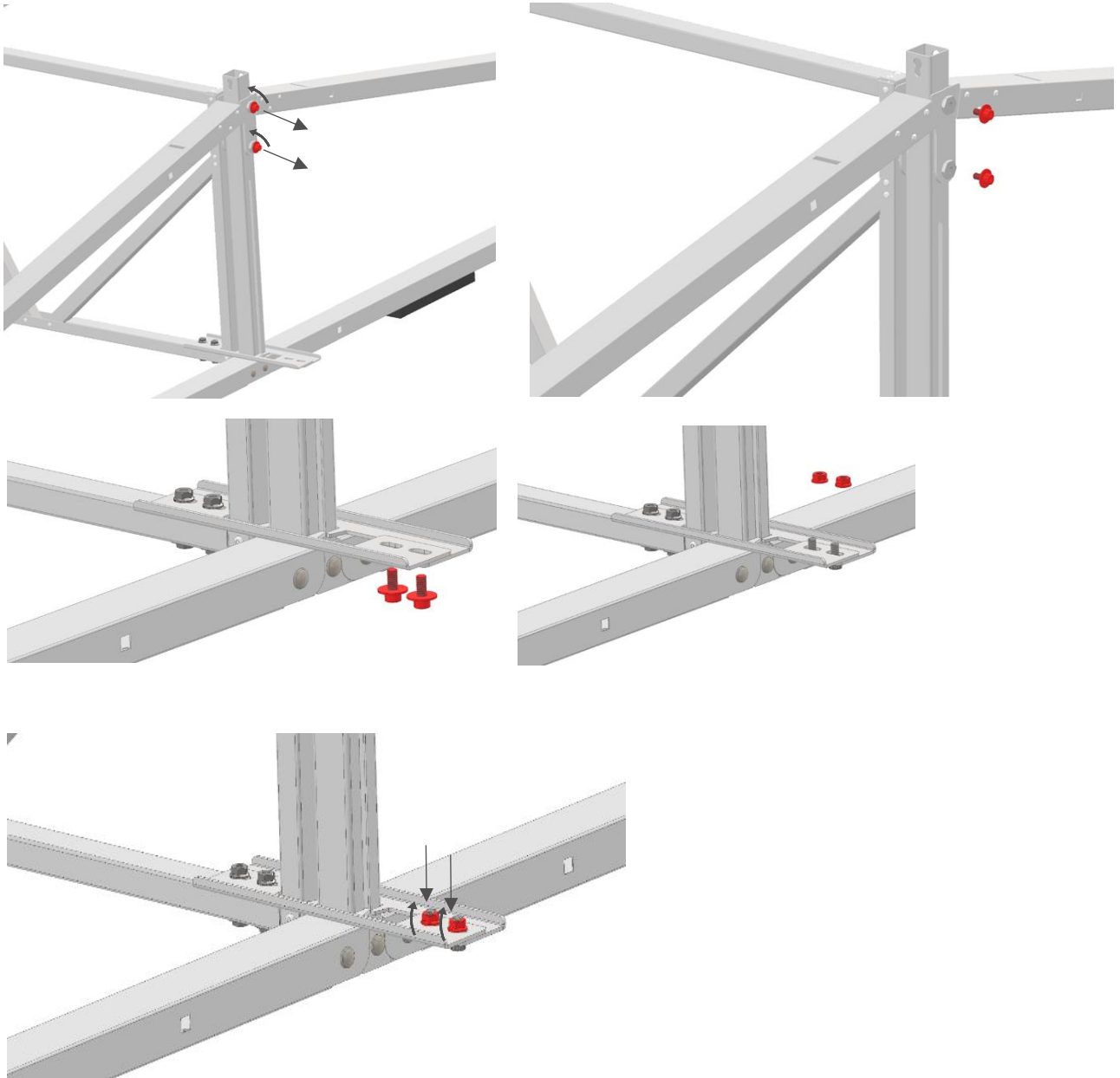

NOTE

Repeat the previous steps for all connecting plates on **the outer ends** of the field.

Tightening all fasteners

Next step is to tighten all the fasteners in the previous step. Check if the system is still aligned before tightening the fasteners. To tighten the fasteners the size #6 allen round head (article number 20-060-0024) is used as well as a **13 mm socket** (article number: 20-060-0033). Tighten the fasteners with a torque of **20-25 N*m**.

NOTE

After tightening all fasteners, the system becomes rigid. Verify that parts haven't been moved, and the system is still aligned.

NOTE

Tighten the fasteners with a torque of **20-25 N*m**



Attachment of the anchors

After tightening all the fasteners, the next step is to attach the mounting structure to the roof anchors. For this step the **R4R Roof anchor connection set** (Article number 10-060-0011) is required for each anchor.

- Place the M10 stainless flange nut (supplied with the roof anchor) on the threaded end of the roof anchor. Place the eye nut of the roof anchor connection set on the threaded end until the thread of the anchor sticks out on the inside of the eye nut. Screw the M10 stainless flange nut towards the eye nut and lock the eye nut and flange nut by turning against each other using the 15 mm wrench.

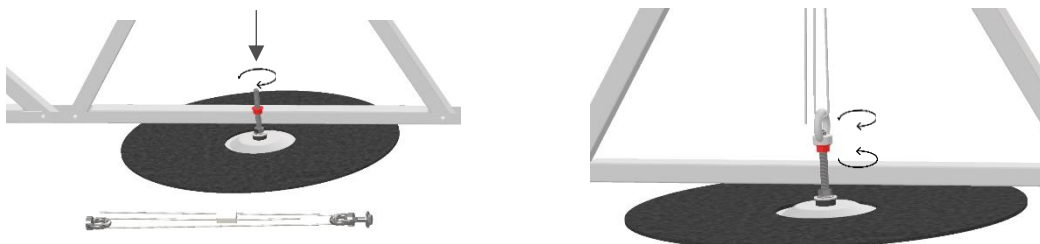

- Unscrew the pre-assembled M10x40 bolt and washer from the second eye nut and place this on the pre-cut hole on top of the center. Attach the eye nut to the bolt **with only a few turns**.



- Take up the slack between the eye nuts, by pulling the two ends of the steel wire.

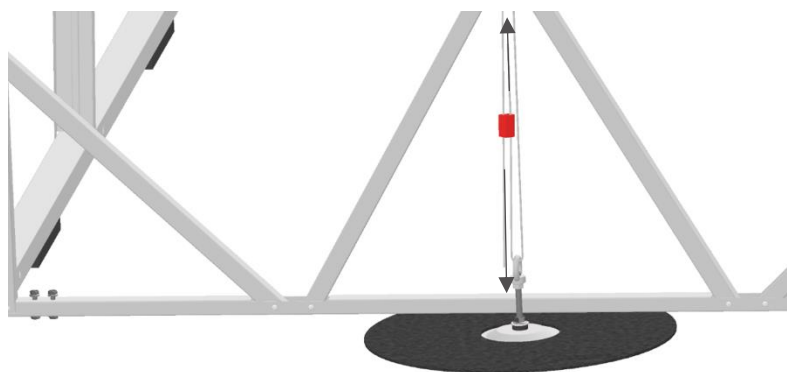

- Next step is to tighten down the upper eye nut using a 17 mm wrench.
If insufficient pre-tension is achieved on the anchor cable, repeat the previous steps to achieve sufficient pre-tension.

NOTE

To achieve sufficient pre-tension, lift the module by the center to see if the sides keep in contact with the roof. Repeat these steps for all anchor locations.

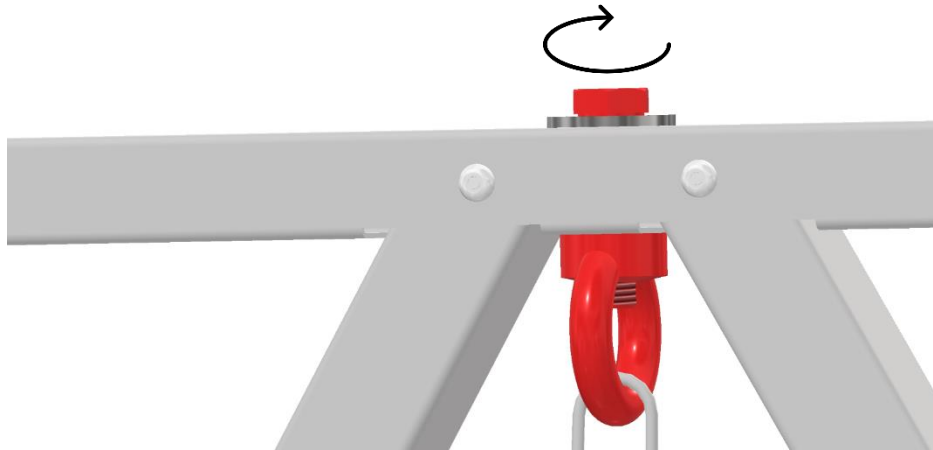

Pre-mounting tension cables

Before placing the solar panels, pre-mounting the tension cables is required. The cables will be tensioned between the sides **after** placement of the solar panels. To attach the cables, attach one side of the cable to the top of the side as depicted in the drawings below.

The cable should face towards the end of the field!

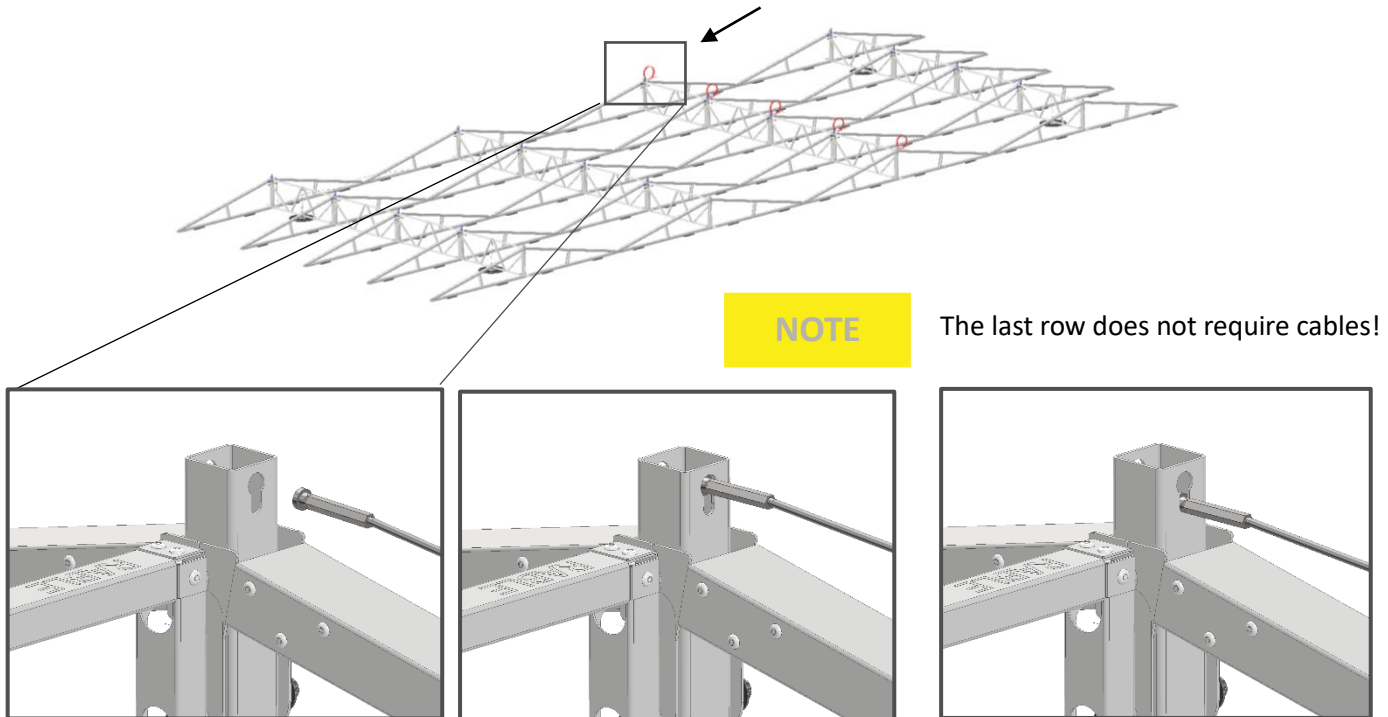

- Repeat these steps for the other rows, where the circles are indicated below.

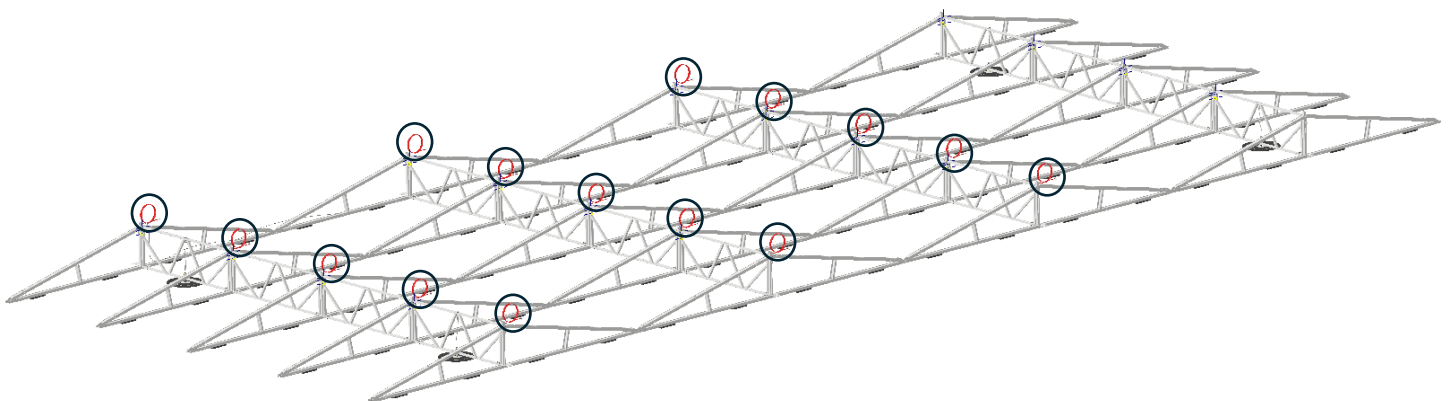

In order to prevent unhooking of the cables on the **first row**, a bolt and nut is attached to the top of the side as depicted in the drawing below.

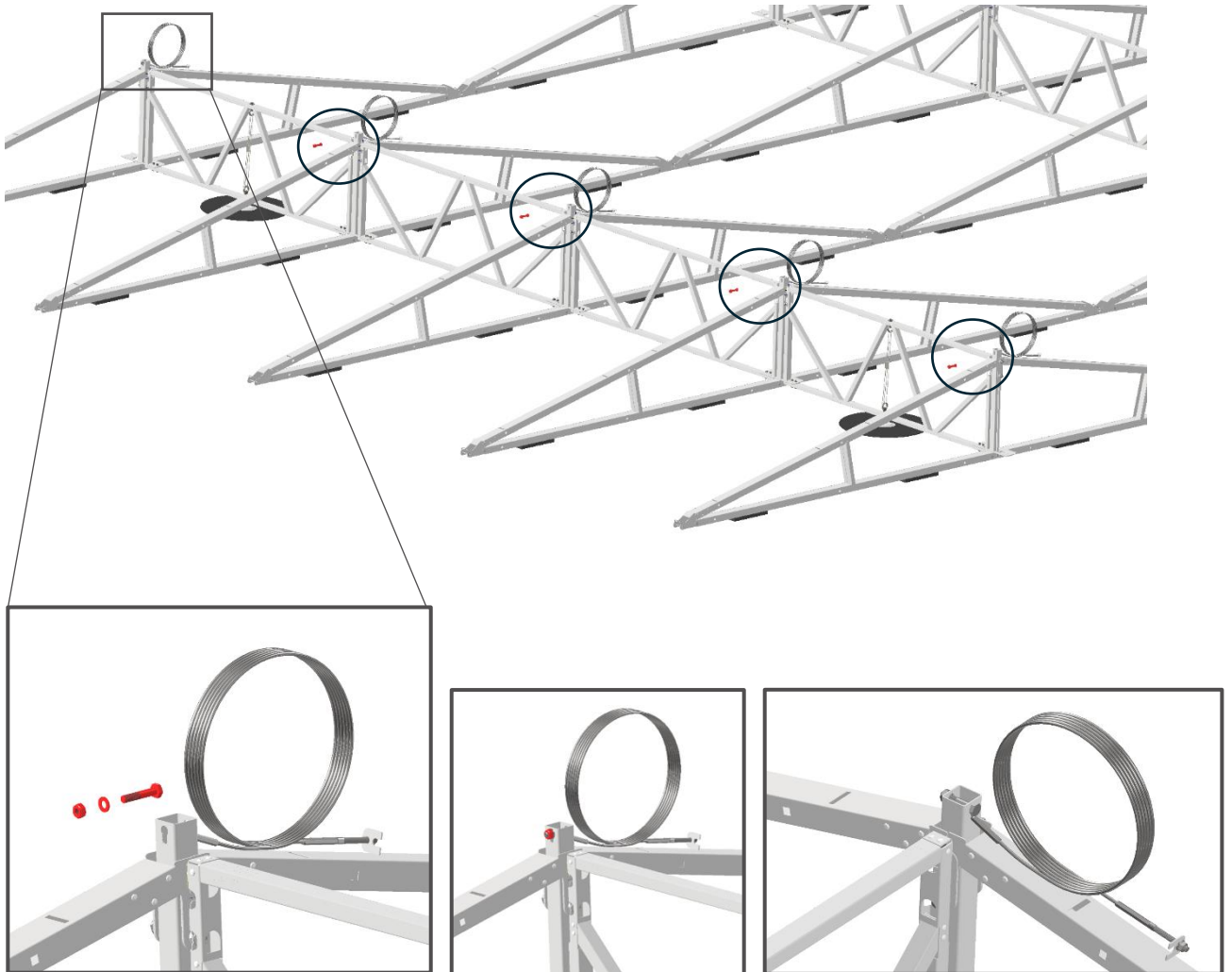

NOTE

This is only required on the first row!

Attachment of optimizers

To attach optimizers, use self-tapping screws and screw this into the pre-drilled hole.

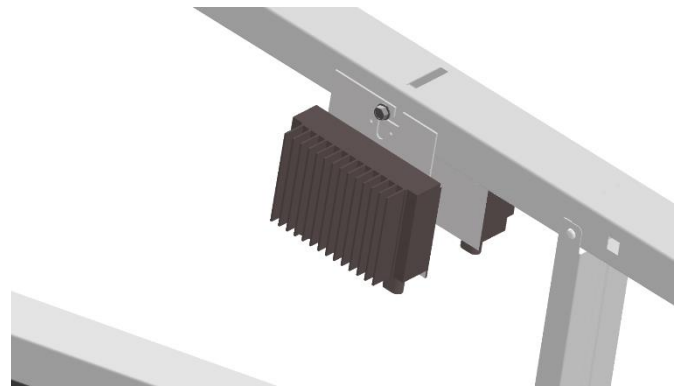
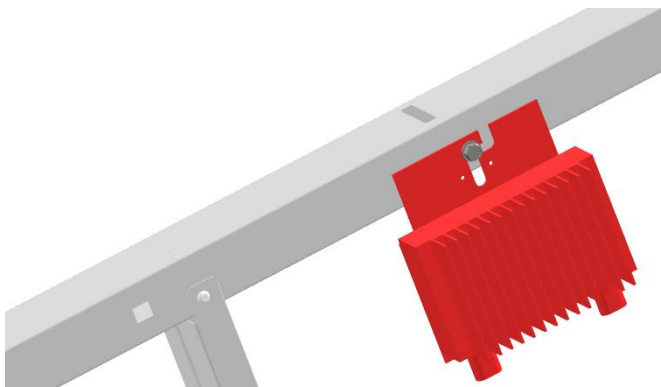
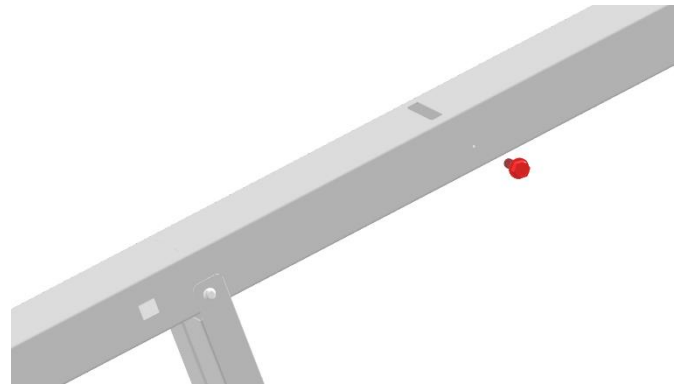
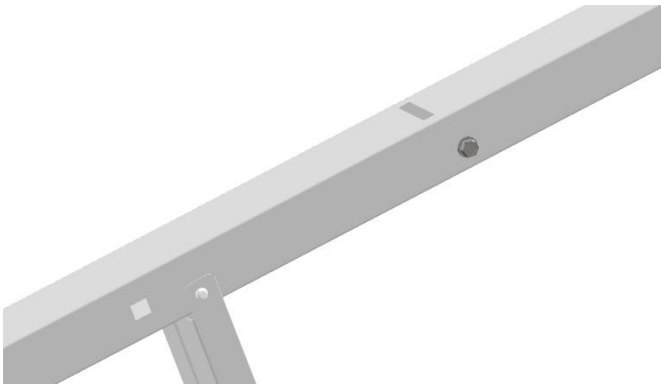

Cable management

To manage the electrical cables, slots have been pre-cut in the sides to attach cable management clips. For the cable management along the length (X-direction) of the system, cable management clips can be placed on either sides of the side.

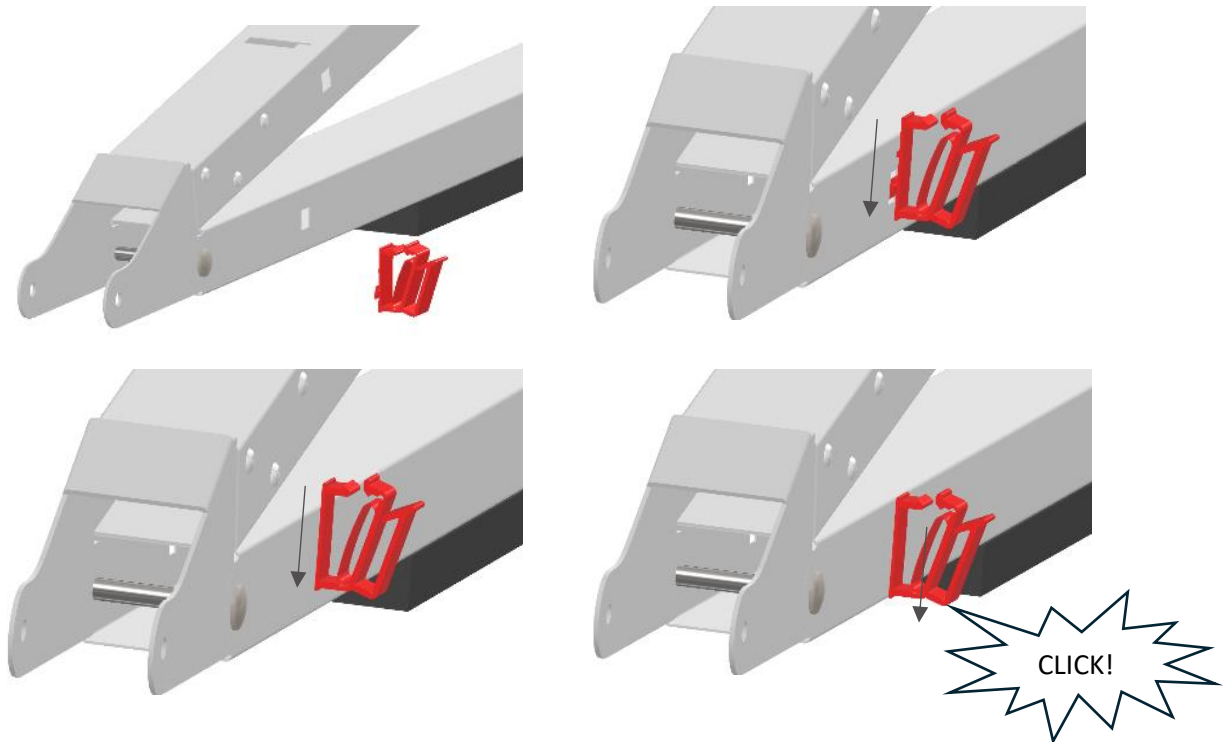

- Cable management clips can be placed on either lower or upper part of the side as depicted in the drawing below.

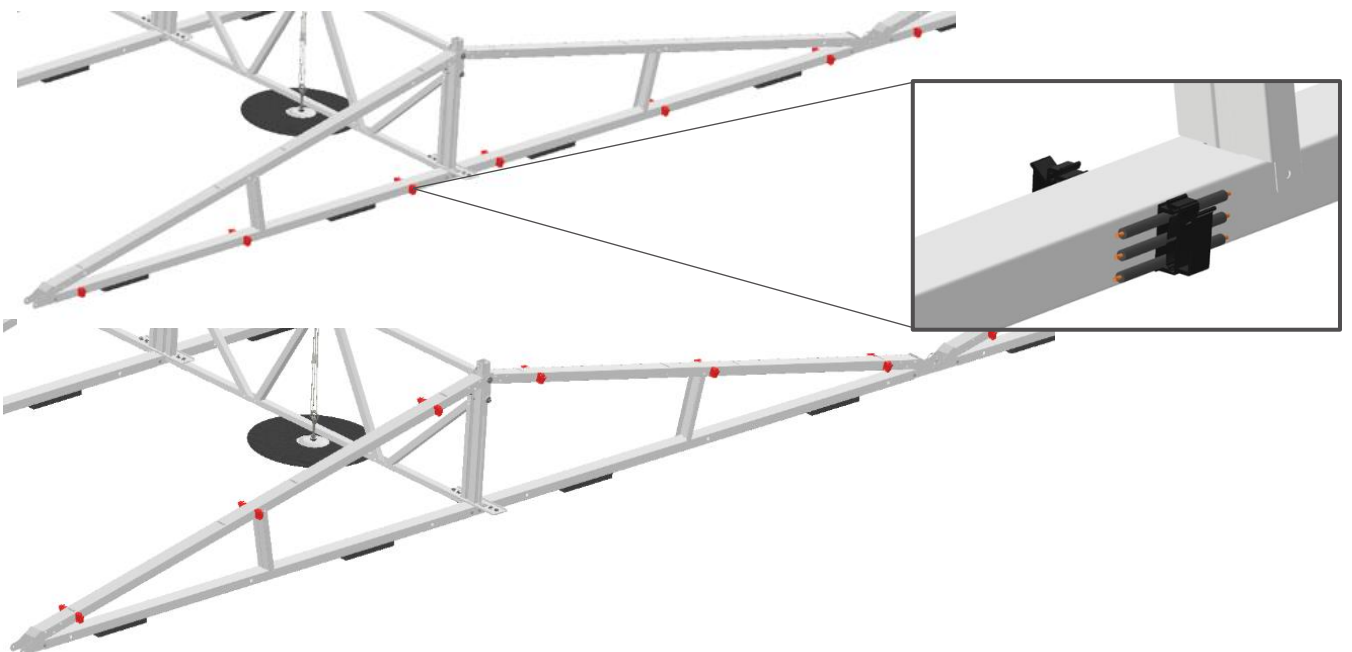

- For the string cables running underneath the panels, the same cable management clips can be mounted underneath the side. The slots are aligned in the middle of the panel. Cables can be placed in the clip, after the required number of cables are placed the clip can be closed. The second hook is used to attach the cables in between the panels.

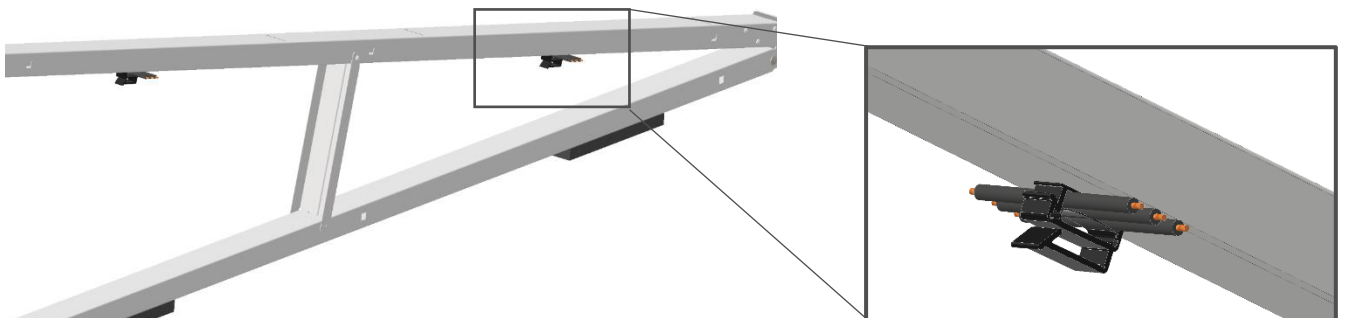
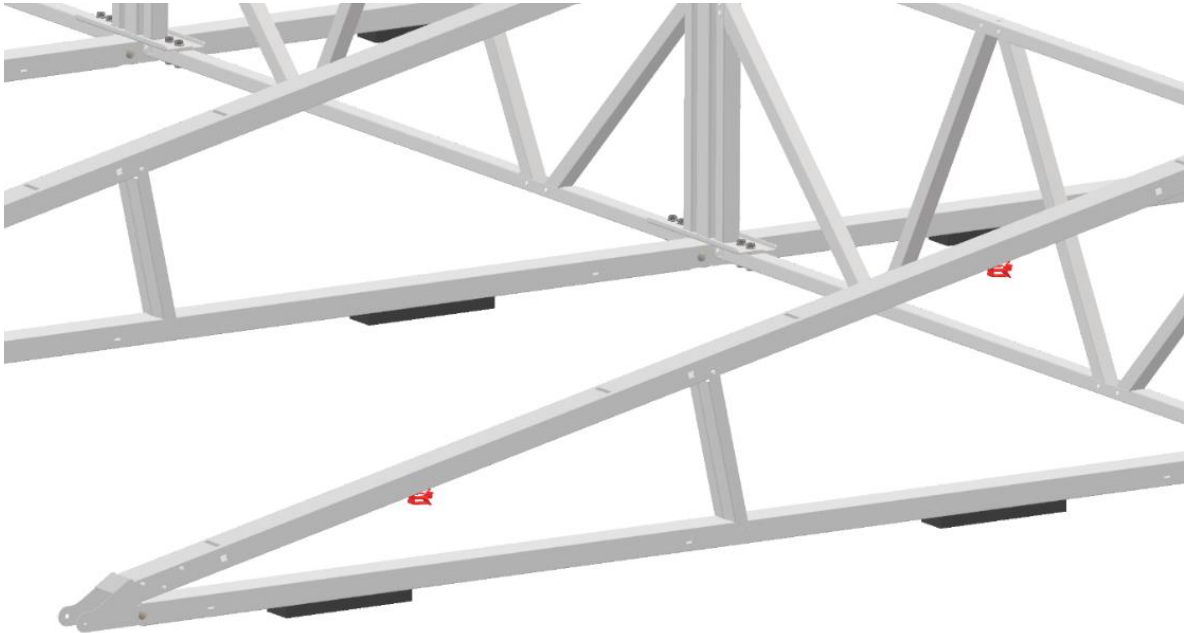

NOTE

Make sure the open section of the cable management clip is facing **upward**.

Mounting of solar panels

- Place the first panel on top of the sides, against the notch. Use the provided end clamps to mount the outer side of the panel, and the middle clamps for the next panel. The clamps are placed by clicking them into the top profile of the side and afterwards tightening the number 6 allen bolt with the provided allen key (Article number 20-060-0023). The required torque for the panel clamps is **10-15 N*m**.

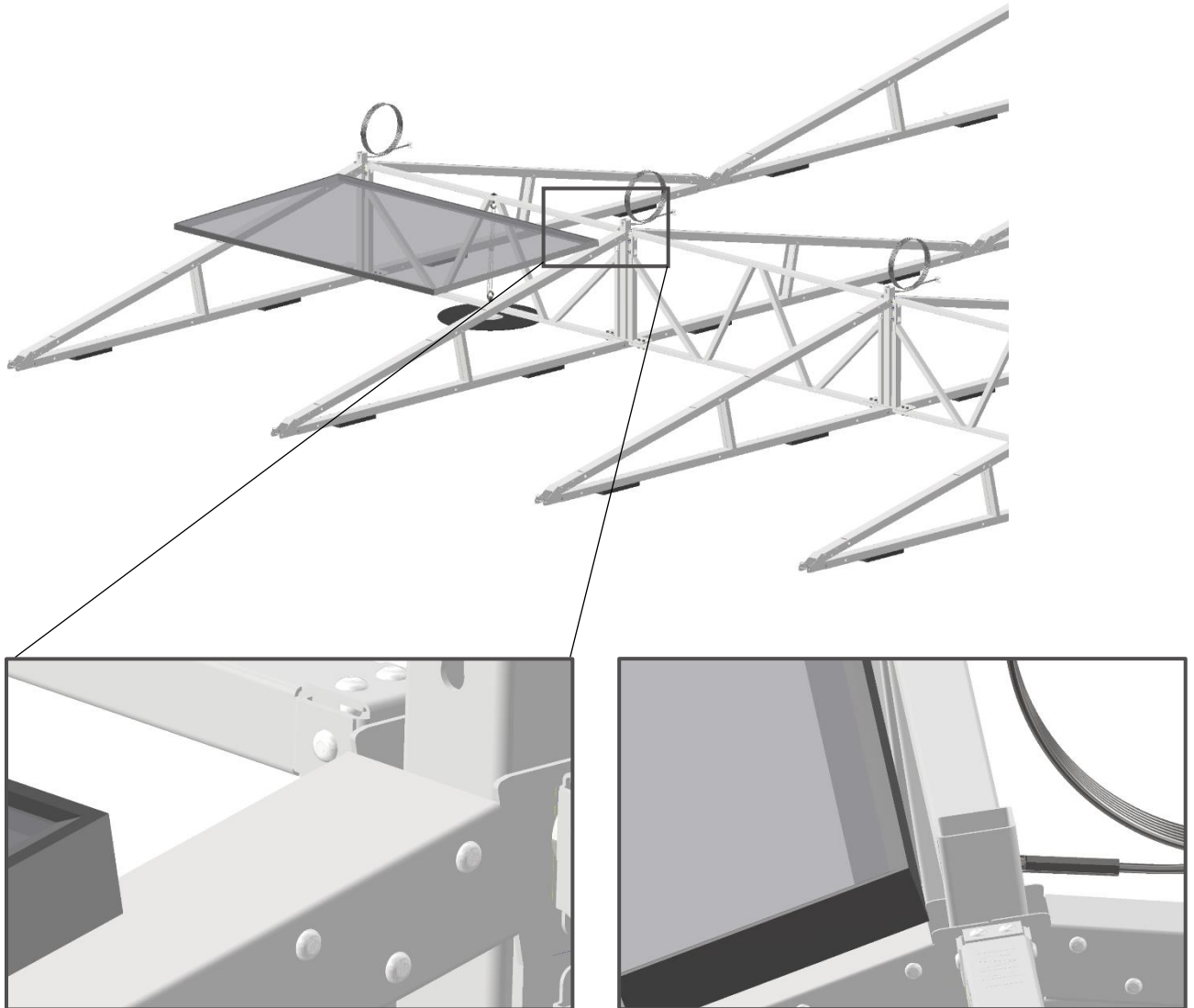

- Place the lower panel against the lower notch and mount the end and middle clamps.

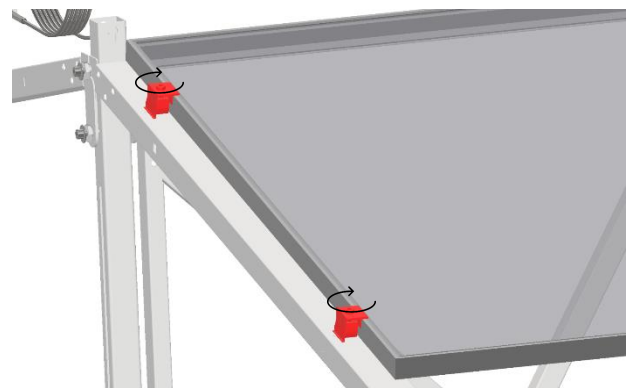
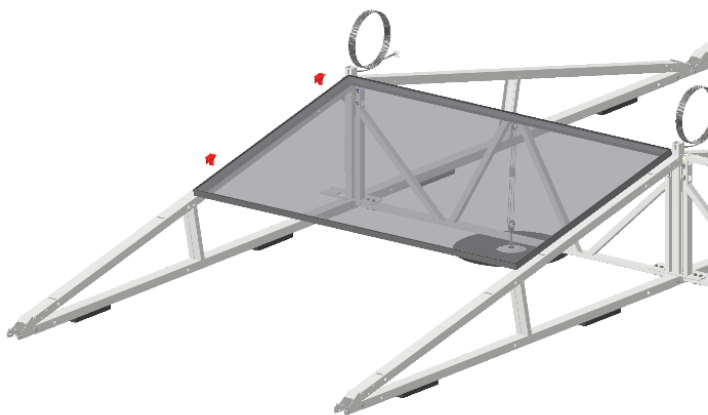
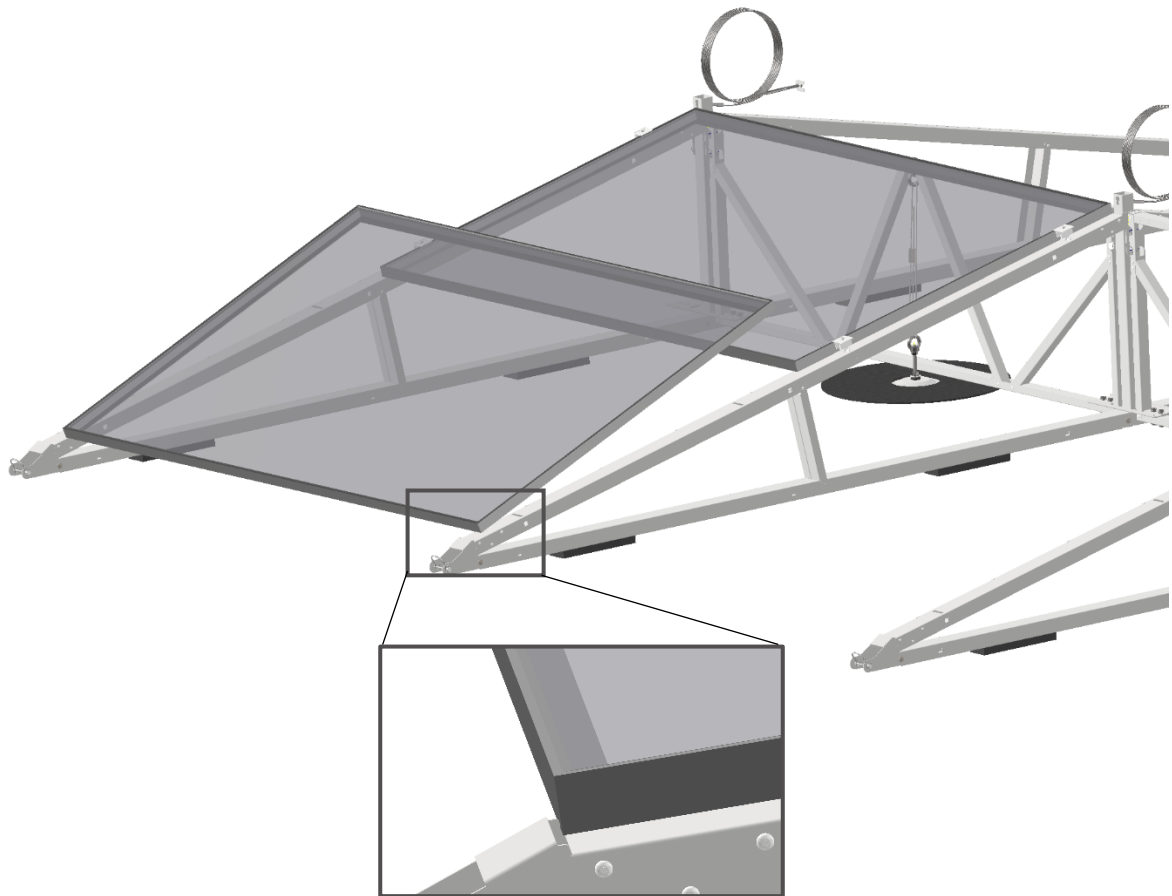

NOTE

Tighten the panel clamps at the **short sides** of the panel, with a torque of 10-15 N*m

- Repeat these steps for the successive panels on the first side of the first row.

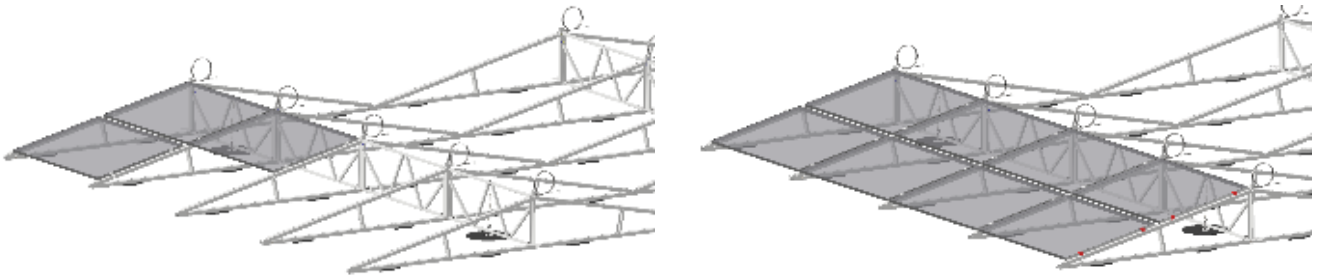

- Follow the placement sequence of the panels as depicted below. The next step is the tensioning of the steel cable between the sides. Tighten the steel cable using the extended 13 mm socket (Article number 20-060-0033) with a torque of **20-25 N*m**. To prevent the steel cable from spinning while tightening, use the provided wrench (Article Number 20-060-0034) or a plier. To prevent friction welding of the stainless-steel nut and threaded end, lubricate the connection and tighten gently.

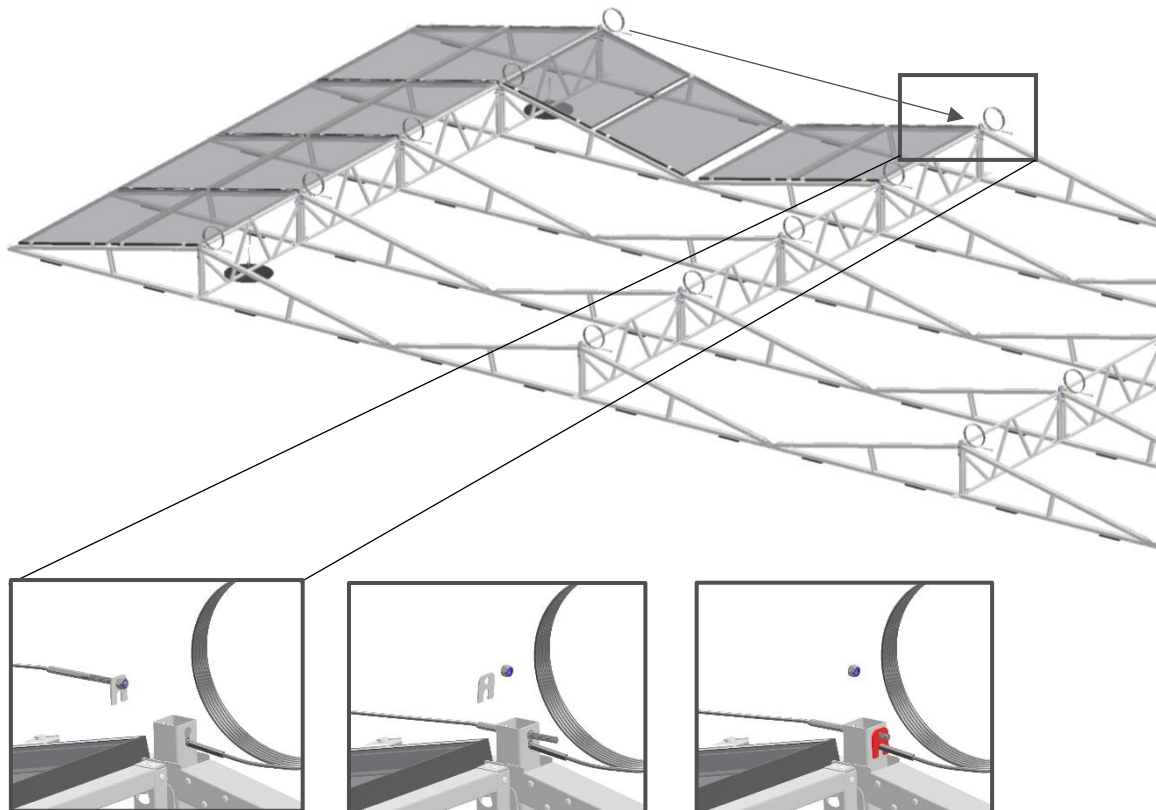

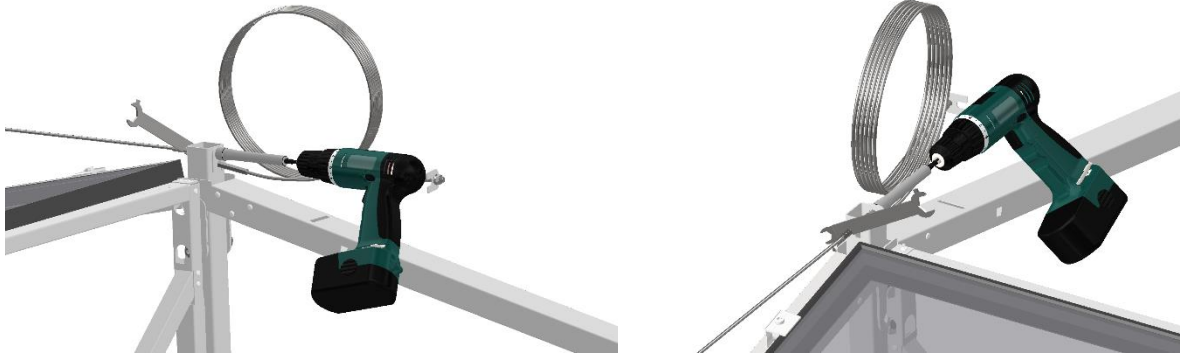

NOTE

Tighten the steel cable with a torque of **20-25 N*m**

To prevent **friction welding** of the nut and threaded end, tighten the nut **gently** and apply lubricant (for example silicone spray or oil film).

- Repeat previous steps as depicted below, until all panels are placed.

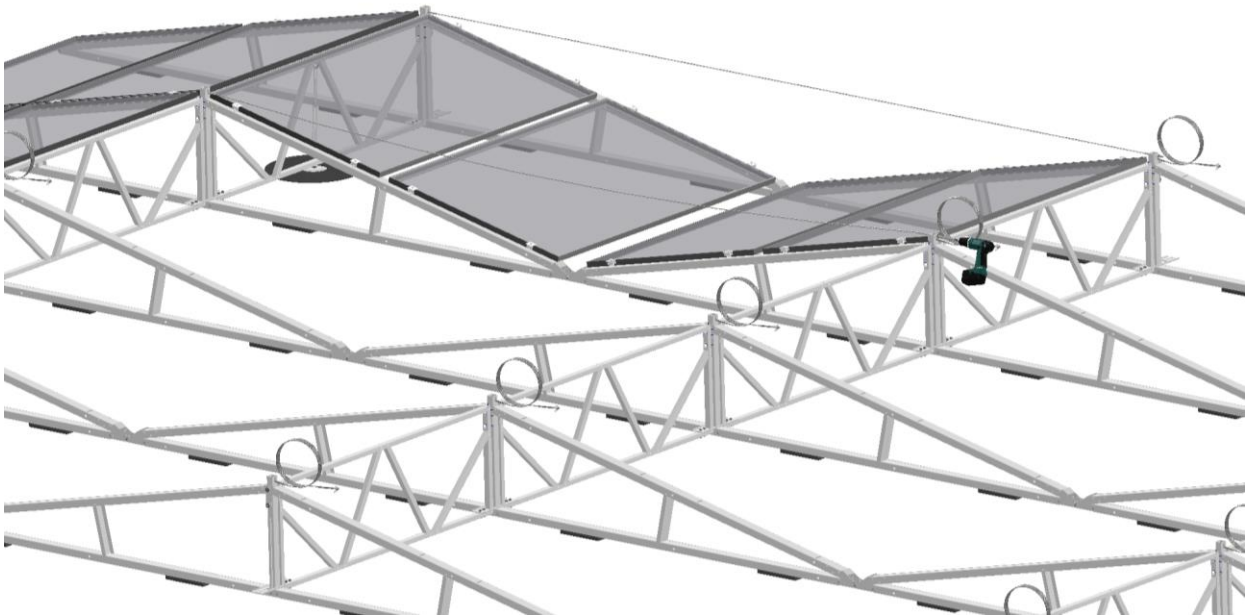

Grounding and potential equalization.

Due to a fully metal mounting system, ground of each field is required **on only one single point**. Ground wires can be attached to one of the outer center brackets, as depicted in the image on the right.

Potential equalization between the panel and the mounting structure is automatically achieved by the pins integrated in the panel clamp. The pins pierce (in case of full black modules) the coating and the aluminium frame for bonding between the frame and the module.

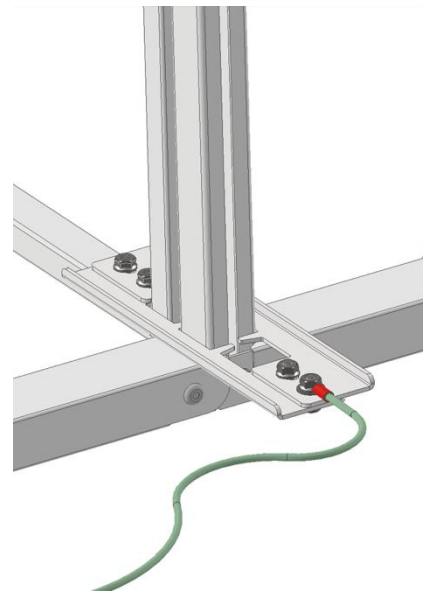

4. Maintenance

To guarantee the safety of the PV-system, RABLE recommends to yearly execute the following inspections:

- Visual inspection of the steel cables. In case tension has been reduced, re-tension according to the required torque described in the manual. Check if the steel cables are not frayed or damaged.
- Visual inspection of the roof anchor connections. In case the connecting cables are slack, re-tension the cables as described in the manual.
- Check that no leaves or vegetation are accumulating under the system. Accumulation can cause heat buildup, which may negatively affect the performance of the installation. Additionally, accumulation can obstruct water drainage, leading to water accumulation.
- Check if the module mounting clamps are still securely fastened. Re-tighten according to the prescribed torque if necessary
- Visual inspection of the mounting system for other loose components, corrosion or damage

Removal and disposal

For the disposal of the product, follow local laws and regulations. All materials can be recycled.