

RABLE Point Load Datasheet



RABLE GROUP B.V.

Authors: *R. Wijnberg & L.J.M. Verhagen*

Version: *4*

Table of Contents

1.	Summary	2
2.	Introduction	3
3.	Insulation as the critical layer under pressure loads	4
4.	Roof membrane.....	5
5.	Insulation types & allowable pressures	6
6.	Roofs with limited bearing capacity & the RABLE mounting system	7
7.	Load Transfer to the Roof Structure	9
8.	Pressure distribution RABLE mounting system with snow	14
9.	Conclusion	16

1. Summary

Installing PV panels on roofs generates point loads at the mounting system's support positions. To prevent damage to the roof insulation, it must be verified that the resulting pressures remain within the limits specified by the insulation manufacturer.

The RABLE system, a rigidly connected mounting system, transfers these loads directly to the main roof structure. This report outlines the point loads and resulting pressures on the insulation. It also discusses commonly used insulation materials and their allowable pressures, examines roofs with limited load-bearing capacity, and provides an overview of the RABLE system.

Calculations are presented for point loads under various spans and panel sizes, including the effect of a load-distribution plate. The report further analyses pressure distribution on the insulation caused by the system, PV panels, and snow load, and concludes with key findings.

2. Introduction

Placing PV panels on roofs creates point loads at the support positions of the PV panel mounting system. To prevent damage to the roof insulation, it is important to verify whether these pressures remain within the limits specified by the insulation manufacturer.

Since the RABLE system is a rigidly connected mounting system, it transfers its loads directly to the main roof structure. To ensure that the point loads do not exceed the insulation limits, this report describes the point loads and the resulting pressures on the insulation.

The next chapter discusses the three different roof layers. In the chapter after, the top layer is discussed. Chapter 5 discusses several commonly used insulation materials and their maximum allowable pressures.

Chapter 6 describes roofs with limited load-bearing capacity, followed by a brief explanation of the RABLE mounting system.

Chapter 7 presents the calculation of point loads imposed by the RABLE system on the main roof structure, for various spans and panel sizes. Sections 7.2 and 7.3 explain the pressure induced by the support feet of the RABLE mounting system, both with and without a load-distribution plate.

Chapter 8 addresses the pressure distribution on the insulation material caused by the mounting system, including the weight of PV panels and snow load.

Chapter 9 presents the conclusions of this report.

3. Insulation as the critical layer under pressure loads

A flat roof typically consists of three main layers: the roof membrane, the insulation, and the roof deck.

The roof membrane forms the top layer and serves as the waterproof barrier of the roof. It is most commonly made of bitumen, but materials such as PVC or EPDM are also frequently used. Its primary function is to prevent water or other substances from penetrating the roof structure.

Beneath the membrane lies the insulation layer, which provides thermal protection for the building. Insulation materials are usually softer products such as PIR, PUR, or mineral wool. This layer helps to retain heat inside the building during colder periods and to maintain a comfortable indoor temperature in summer.

The roof deck forms the bottom layer of the roof system. It can consist of sheet metal or a concrete slab and provides structural support by connecting the underlying beams to the layers above.

Of these three layers, the insulation is the most sensitive to pressure loads caused by rooftop installations, such as solar panels. Manufacturers typically provide datasheets specifying the maximum allowable compressive stress for their insulation products. It is important that equipment placed on the roof does not exceed these limits or damage the insulation layer. The roof membrane, by contrast, generally has a higher resistance to pressure due to its elastic properties.

For insulation materials, a distinction is made between short-term and long-term load capacity. The allowable short-term compressive stress is usually about three times higher than the allowable long-term value. Similarly, the permissible deformation under short-term load is around 10% of the insulation thickness, while for long-term loads it is typically limited to 2–5%, depending on the type of insulation used.

4. Roof membrane

The top layer of the roof is the roof membrane. This layer mainly functions as the waterproofing layer and has no load bearing capacity. Typical examples of this membrane are bituminous, EPDM or PVC.

Each waterproofing layer is not a load-bearing element and therefore does not have an admissible uniform load in kN/m^2 . In accordance with EN 13707, performance is assessed by EN 12730 (resistance to static load) and EN 12691 (resistance to impact). With the prescribed load-distribution layer and the avoidance of concentrated point loads achieved due to by the support feet underneath the system (see Chapter 6.2), the risk of damage to the membrane due to the intended installations is considered low.

5. Insulation types & allowable pressures

In this chapter, specifications for various types of commonly used insulation materials are shown. The insulation manufacturers' specifications should be applied to verify if the pressures caused by the RABLE mounting system, calculated in the next chapters, exceeds the allowable pressures of the insulation.

Deformation of insulation

According to EN 826 the compressive strength of insulation is typically defined at 10% for permanent load. In practice this differs per material. Because of this deformation, minimal insulation thickness is required. However, in practice, the permissible deformation is significantly lower and depends on the specific material type. To prevent damage to the roof assembly, a minimum insulation thickness is required.

Table 1 provides recommended minimal insulation thicknesses for different materials. If a building uses different insulation material or deviates from the listed configurations, please contact RABLE for a project-specific assessment.

As can be seen in the tables in chapter 4, **if the applied pressure is lower than the compressive strength of the insulation, there is no minimal required insulation thickness.**

Table 1 Insulation types

Insulation material	Compressive strength [kPa]	Minimal insulation thickness [mm]
PIR / PUR	120-200	100
XPS	300-700	NA*
EPS	100-200	100
Phenolic foam	150-200	100
Mineral wool / Rock wool	30-80	40
Foam glass (Cellular glass)	600-900	NA*
Wood fiber boards	50-150	40

* No support feet required due to high compressive strength

Note: This table is only an indication for different types of insulation materials. Always check the maximum allowable pressure using insulation manufacturers' specifications

From Table 1, it is clear that the lowest allowable pressure applies to Mineral wool / Rock wool, with a maximum permissible pressure between 30 and 80 kPa.

In the next chapter, a brief explanation of roofs (or roof plates) with limited bearing capacity is described and how the RABLE system is designed for these weak roofs.

6. Roofs with limited bearing capacity & the RABLE mounting system

In this chapter, a description of roofs with limited bearing capacity, also known as weak roofs, is given. Subsequently the working principle of the RABLE mounting system, designed for these weak roofs, is briefly described.

6.1 Roofs with limited capacity

The roofs of industrial buildings are often designed for bearing roof plates, insulation and watertight membrane in combination with snow and wind loads. Additional (high) loads caused by for example ballasted PV-systems, generally exceed the bearing capacity of the roof plates. The main roof structure is mostly able to bear additional loads. The roof plates and insulation generally are the limiting factor.

In general, this problem can be divided into two sections:

1. *The roof plates can bear a limited amount* of additional loads (on top of the calculated snow and wind loads)
2. *The roof plates cannot bear additional loads* (on top of the calculated snow and wind loads).

6.2 The RABLE mounting system

The RABLE mounting system is developed for roofs that are not capable of bearing additional high loads or any additional loads on their roof plates. The system is developed as a so-called “roof on roof” structure capable of spanning from purlin to purlin, avoiding additional load on the roof plates.

The systems’ extreme rigidity has two beneficial features for PV installations on weak roofs :

1. Lightweight - The solar panels weight acts collectively, eliminating the need for ballast. The rigid system integrates the PV panel weight across the field, serving as the “ballast” against uplift. This way the system eliminates the need for ballast up to a certain wind load, in certain configurations. Depending on the configuration (glued) roof anchors may be required at field edges.
2. No renovation needed - PV installation load is diffused to roof structure (beams / purlins / girders) avoiding adding additional load to the roof plates.

In Figure 1 The RABLE mounting system placed on a roof structure, the RABLE mounting system is placed on top of a roof structure without roof plates, illustrating the load diffusion principle. From this figure it can clearly be seen that the system does not load the roof plates, while the system is carried by the (wooden) main roof structure.

From this figure it is visible that the system imposed point loads on the main roof.

In the next chapter, these imposed point loads are calculated, which changes depending on the span between the girders and the length of the panel. In the sub-paragraphs, the pressures



Figure 1 The RABLE mounting system placed on a roof structure

7. Load Transfer to the Roof Structure

This chapter describes how the loads of the RABLE mounting system including the PV panels are transferred to the main roof structure. Subsequently the pressures underneath the support feet are calculated for various spans and panel sizes.

7.1 Point loads imposed by the RABLE mounting system on the main roof structure

In this paragraph the point loads imposed by the RABLE system on the main roof structure are related to 2 variables:

1. The distance (span) between the roof beams
2. The dimensions (length and weight) of the panel

In Figure 2, a principle drawing of the RABLE mounting system with various roof beam spans is shown. Longer spans lead to higher loads. For clarity purposes the roof plate, insulation and waterproofing membrane have been removed.

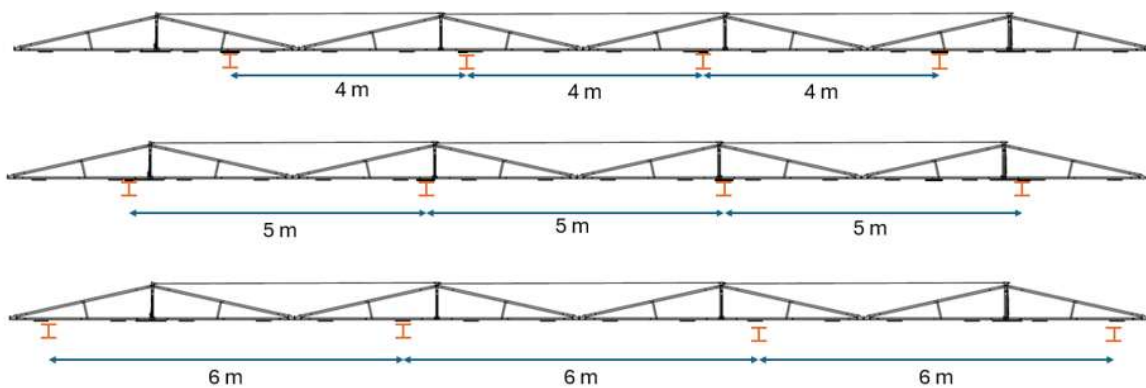

Figure 2 The RABLE mounting system with various spans (4,5 & 6m)

In Figure 3, a principle drawing of the RABLE mounting system in the width dimension is shown. Larger panels lead to higher loads. The figure shows how the distances between the sides are impacted, depending on the dimensions of the solar panels.

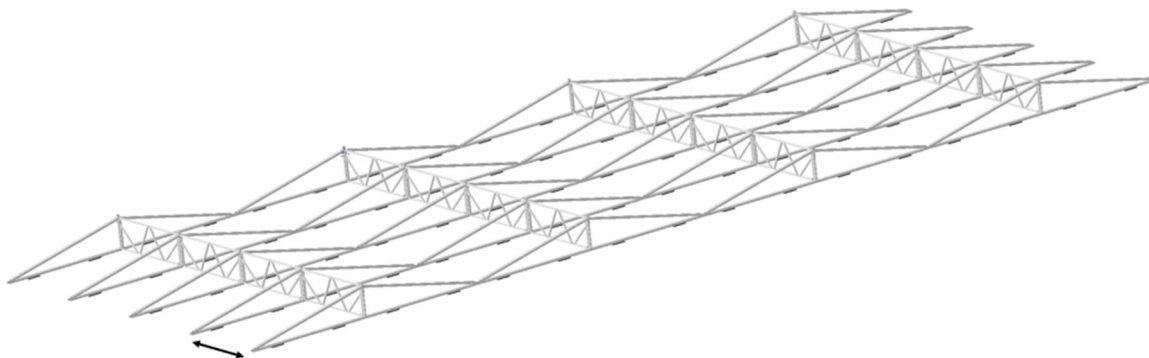

Figure 3 Length of the panel

In Table 2 the maximum point loads of the RABLE mounting system on the roof beams, related to the size of the solar panel and the span between the beams, are shown. For these point-loads the following values for the RABLE mounting system and weight of the PV-panels are used, for the glass-foil panels:

$$q_{pv} + q_{RABLE} = 12.5 \frac{kg}{m^2}$$

For the lightweight panels:

$$q_{pv} + q_{RABLE} = 7 \frac{kg}{m^2}$$

The point loads shown in the table are the most loads in the middle of the field. These points generate the highest loads. The loads on the edge of the field are lower. The maximum point load (F_p) is generally determined by the formula below:

$$F_p = g * q_{pv} * beam\ span * length\ of\ panel$$

Table 2 Point loads of mounting system on location of roof beams

Point load [N]	Standard panels (Glass-foil)			Lightweight panels		
	1762	1903	2278	1762	1903	2278
Beam span [m]						
4	864	933	1117	484	523	626
5	1080	1167	1397	605	653	782
6	1296	1400	1676	726	784	939
7	1512	1633	1955	847	915	1095
8	1729	1867	2235	968	1045	1251
9	1945	2100	2514	1089	1176	1408
10	2161	2334	2793	1210	1307	1564

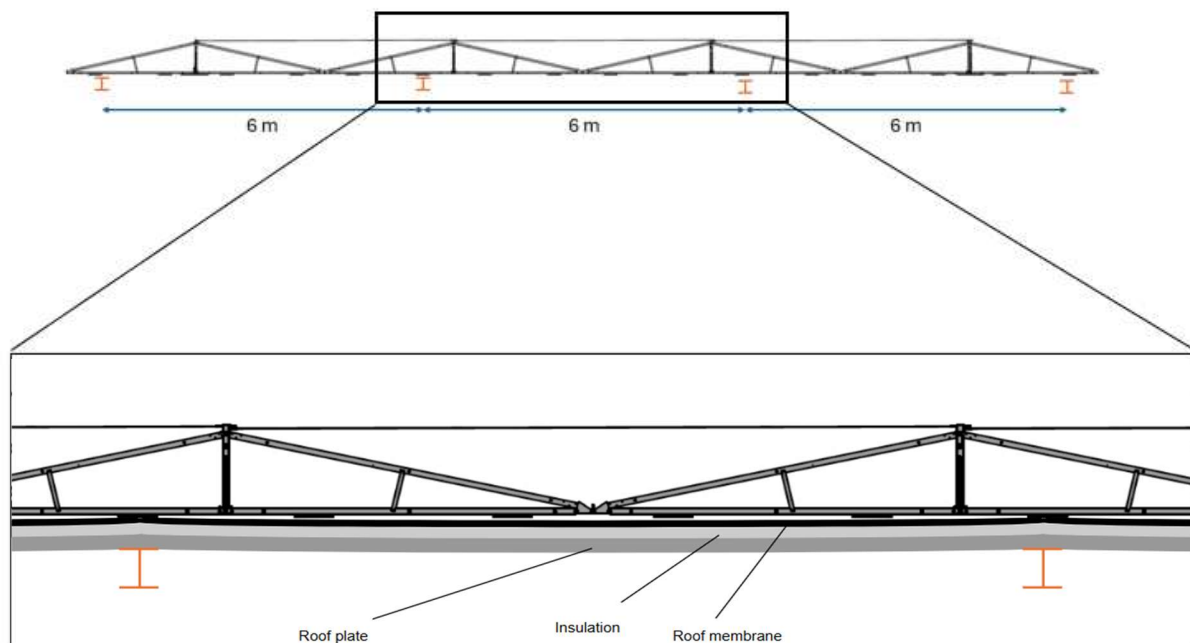

Figure 4 Detail of point loads

In the next two paragraphs, the pressure underneath the feet is calculated for **single** and **multiple** pressure dividing support feet.

7.2 Support feet pressures at main support structure for one support foot

The point loads of the RABLE mounting system imposing are transferred to the roof by rubber granulate support feet. In The pressure of the area is determined by the support feet. The support feet have a dimension of 250x60mm. The pressure is determined by the area of a support f_{oot} , the mass on this foot and the additional load spreading from the top layer.

Note. In the pressure calculation below it is considered that the system is completely supported on the girders (spanned) and therefore results in pressure on the section above the girders only. Depending on the stiffness of the roof plates, pressures become lower when the roof plates stiffness increases due to more feet touching the roof next to the girder (see Figure 8 & Figure 9), and pressure is divided and therefore lower.

Table 3 the maximum pressures imposed by the RABLE system on the insulations based on one support foot is shown.

In **Fout! Verwijzingsbron niet gevonden.** the dimensions of the support feet are given.

The pressure of the area is determined by the support feet. The support feet have a dimension of 250x60mm. The pressure is determined by the area of a support foot, the mass on this foot and the additional load spreading from the top layer.

Note. In the pressure calculation below it is considered that the system is completely supported on the girders (spanned) and therefore results in pressure on the section above the girders only. Depending on the stiffness of the roof plates, pressures become lower when the roof plates stiffness increases due to more feet touching the roof next to the girder (see Figure 8 & Figure 9), and pressure is divided and therefore lower.

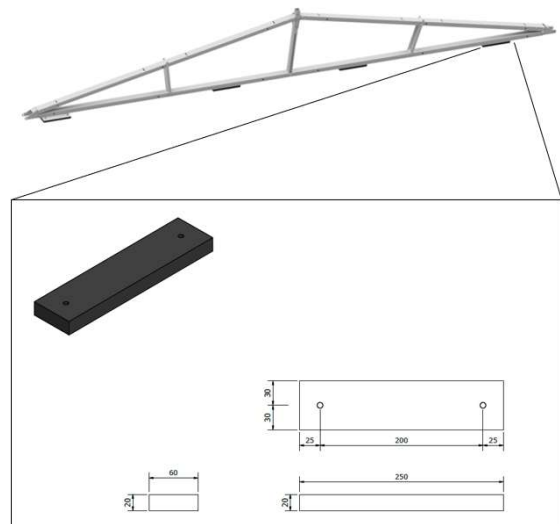

Figure 5 Support feet dimensions one support foot

Table 3 Pressure (kPa) with one support foot

Point pressure [kPa]	Standard panels (Glass-foil)			Lightweight panels		
	1762	1903	2278	1762	1903	2278
Beam span [m]						
4	47.5	51.3	61.4	26.6	28.7	34.4
5	59.4	64.1	76.7	33.2	35.9	43.0
6	71.2	76.9	92.1	39.9	43.1	51.6
7	83.1	89.8	107.4	46.5	50.3	60.2
8	95.0	102.6	122.8	53.2	57.4	68.8
9	106.8	115.4	138.1	59.8	64.6	77.4
10	118.7	128.2	153.5	66.5	71.8	86.0

Note that load spreading from the support feet is also taken into account.

7.3 Support feet pressures at main support structure for three support feet (using pressure distribution plate)

For higher spans, or for insulation with lower allowable pressures, a pressure distribution plate can be used. The single rubber support foot is removed, the pressure distribution plate including three rubber support feet are attached to the underside of the profile. By adding the pressure distribution plate and two extra rubber feet, the area is three times higher. In this way the loads described

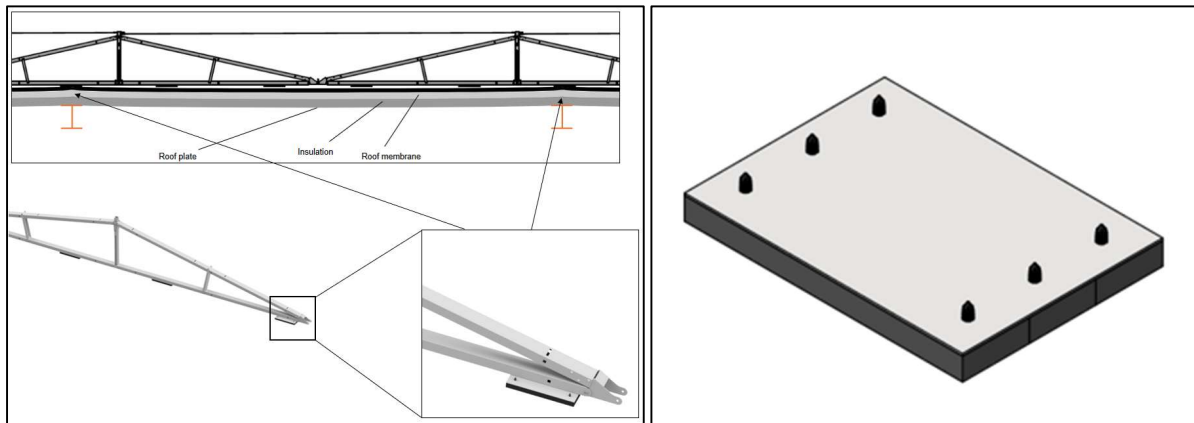

Figure 6 distribution plate with three support feet (left) and pressure distribution plate (right)

With three feet, the pressures at each point for the different spans and panel sizes are determined in Table 4.

Note. In the pressure calculation below, it is considered that the system is completely supported on the girders (spanned) and therefore results in pressure on the section above the girders only. Depending on the stiffness of the roof plates, pressures become lower when the roof plates stiffness increases due to more feet touching the roof next to the girder (see Figure 8 & Figure 9), and pressure is divided and therefore lower.

Table 4 Pressure (kPa) with three support feet

Point pressure [kPa]	Standard panels (Glass-foil)			Lightweight (Light weight)		
	1762	1903	2278	1762	1903	2278
Beam span [m]						
4	17.5	18.9	22.6	9.8	10.6	12.7
5	21.9	23.6	28.3	12.2	13.2	15.8
6	26.2	28.3	33.9	14.7	15.9	19.0
7	30.6	33.1	39.6	17.1	18.5	22.2
8	35.0	37.8	45.2	19.6	21.2	25.3
9	39.4	42.5	50.9	22.0	23.8	28.5
10	43.7	47.2	56.5	24.5	26.5	31.7

Note that load spreading from the support feet is also taken into account.

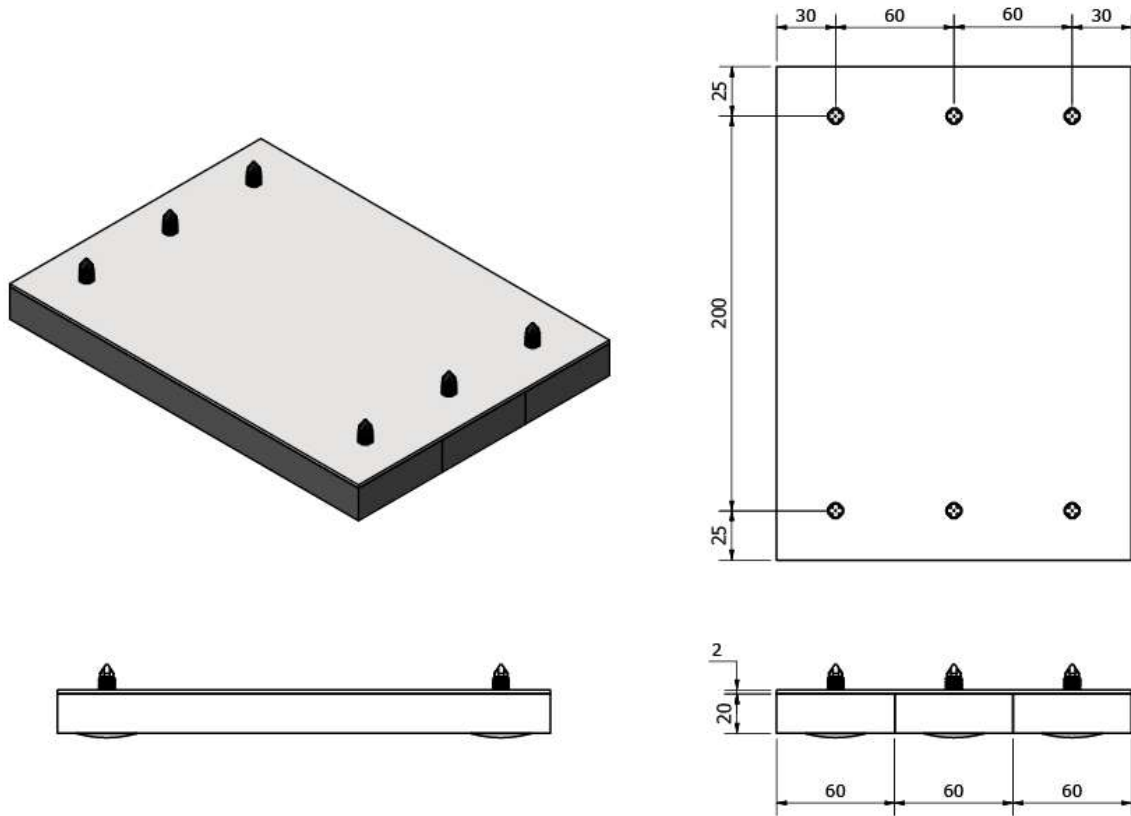

Figure 7 Dimensions of distributing plate with three support feet

8. Pressure distribution RABLE mounting system with snow

For variable temporary loads (wind & snow), the additional support feet underneath the mounting system assure an equal pressure distribution of the variable temporary loads. In the table below the pressures underneath the support feet for different snow loads and panel sizes is given.

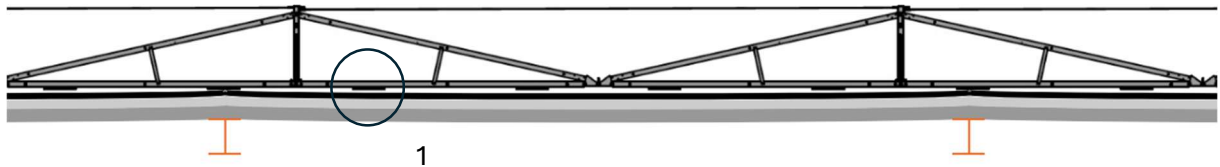

Figure 8 RABLE mounting system without snow

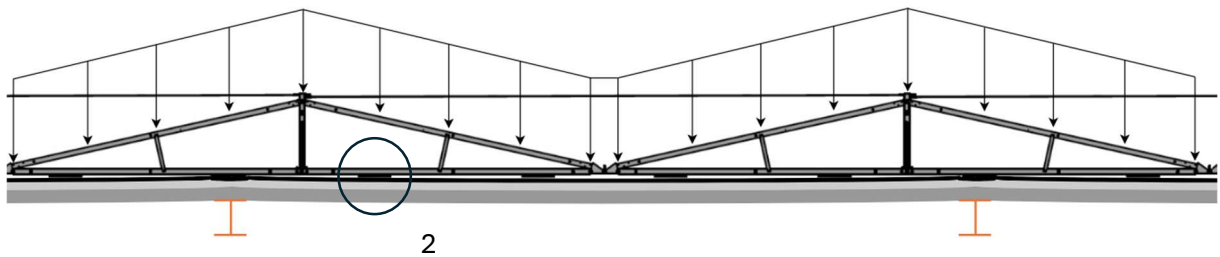

Figure 9 RABLE mounting system with snow

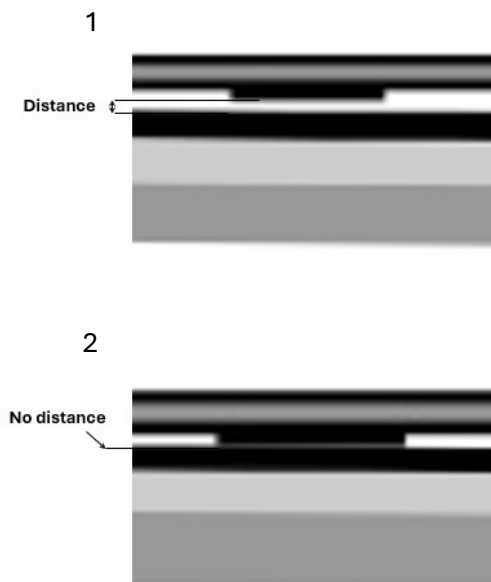

Figure 10 Difference with and without snow

The RABLE mounting system has 4 support feet by default. It is possible to add more feet, distributing the load to more points. Refer to the [manual](#) for the placement of [additional feet](#). The tables below show the dynamic point load on these support feet.

Snow loads are considered as dynamic load, Table 1 considers static load only. The dynamic load limit is most of the times higher than the static load. Please check this with the supplier.

Table 5 Point pressure under supports with snow load, default system

Point pressure [kPa]	Length of panel [mm]		
Snow load (kg/m ²)	1762	1903	2278
50	72.6	78.4	93.9
60	83.7	90.4	108.2
70	94.7	102.3	122.5
80	105.8	114.3	136.8
100	127.9	138.1	165.4
150	183.2	197.9	236.9
200	238.5	257.6	308.4
250	293.8	317.4	379.9

Table 6 Point pressure under supports with snow load, 5 support feet

Point pressure [kPa]	Length of panel [mm]		
Snow load (kg/m ²)	1762	1903	2278
50	58.1	62.7	75.1
60	66.9	72.3	86.5
70	75.8	81.8	98.0
80	84.6	91.4	109.4
100	102.3	110.5	132.3
150	146.6	158.3	189.5
200	190.8	206.1	246.7
250	235.1	253.9	303.9

Table 7 Point pressure under supports with snow load, 6 support feet

Point pressure [kPa]	Length of panel [mm]		
Snow load (kg/m ²)	1762	1903	2278
50	48.4	52.3	62.6
60	55.8	60.2	72.1
70	63.1	68.2	81.6
80	70.5	76.2	91.2
100	85.3	92.1	110.2
150	122.1	131.9	157.9
200	159.0	171.7	205.6
250	195.9	211.6	253.3

9. Conclusion

In this report the working principles of RABLE's "roof on roof" system are outlined in the first chapters. This explains why the system is lightweight, spreading weight evenly over the whole installation and diffusing load to the roof structure.

Further details are provided on the point loads that the system imposes on the insulation and roof beams, depending on two key variables : roof beam distance and panel dimensions.

The resulting point load tables can be used to assess whether load limits of the insulation or underlying roof membrane are reached. The tables indicate that RABLE can be applied with nearly all insulation and roof membrane types. A load distribution plate may be used for cases where the limits appear to be exceeded.

For explanations, advice or further details please connect with RABLE at: support@rable.com